

➤ Instructions



Thule ReVert 6 Bike
9026500



**EN**

IMPORTANT - READ THE INSTRUCTIONS CAREFULLY BEFORE USE AND KEEP FOR FUTURE REFERENCE.



Symbols

-  **WARNING** indicates a hazardous situation which, if not avoided, could result in death or serious injury.
-  **CAUTION** indicates a hazardous situation which, if not avoided, could result in minor or moderate injury.
-  **Note** indicates additional information that is useful for trouble-free and optimal use of the product.

ES

IMPORTANTE - LEER LAS INSTRUCCIONES CUIDADOSAMENTE ANTES DEL USAR Y CONSÉRVELAS PARA FUTURA REFERENCIA.



Símbolos

-  **ADVERTENCIA** indica una situación de posible peligro que, si no se evita, podría provocar lesiones graves o incluso la muerte.
-  **ATENCIÓN** indica una situación peligrosa que, si no se evita, podría provocar lesiones leves o moderadas.
-  **NOTA** indica información adicional que es útil para un uso óptimo y sin problemas del producto.

FR

IMPORTANT - LISEZ ATTENTIVEMENT LES INSTRUCTIONS AVANT UTILISATION ET CONSERVEZ-LES POUR RÉFÉRENCE FUTURE.



Symboles

-  **AVERTISSEMENT** indique une situation potentiellement dangereuse qui, si elle n'est pas évitée, pourrait provoquer des blessures graves, voire mortelles.
-  **ATTENTION** indique une situation potentiellement dangereuse susceptible qui, si elle n'est pas évitée, peut entraîner des blessures mineures ou modérées.
-  **REMARQUE** indique comment répondre à une situation donnée et vous donnent des conseils sur le fonctionnement des options disponibles.

PT

IMPORTANTE - LER CUIDADOSAMENTE AS INSTRUÇÕES ANTES DE USAR E GUARDÁ-LAS PARA FUTURA REFERÊNCIA.

Símbolos

-  **ATENÇÃO** indica uma situação perigosa que, se não for evitada, pode resultar em morte ou ferimentos graves.
-  **CUIDADO** indica uma situação perigosa que, se não for evitada, pode resultar em ferimentos ligeiros ou moderados.
-  **NOTA** indica informações adicionais que são úteis para a utilização ideal e sem problemas do produto.

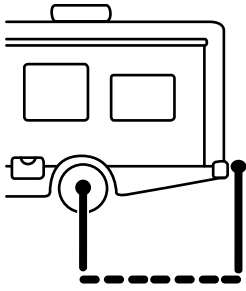

7.5 Ft / 230 cm

EN

The maximum permitted load of this carrier must not exceed 60% of its rated capacity (i.e., 40% total load reduction) when mounted on:

- cargo vans,
 - passenger vans,
 - van conversions,
- regardless of rear overhang length.

The same 60% load limitation also applies when mounted on any other motorized RV* with a rear overhang exceeding 230 cm (7.5 ft), measured from the center of the rear axle to the most distant rear point of the vehicle.

WARNING: This carrier is not compatible with travel trailers/caravans, 5th wheels, or any bumper-mounted hitch receiver.

*"Motorized RV" as defined in 49 CFR 571.3(c), "Motor home," National Highway Traffic Safety Administration, U.S. Department of Transportation.

FR

La charge maximale autorisée de ce porte-vélos ne doit pas dépasser 60 % de sa capacité nominale (c.-à-d. réduction de 40 % de la charge totale) lorsqu'il est monté sur :

- fourgons de fret,
 - fourgonnettes,
 - fourgons convertis,
- quelle que soit la longueur du porte-à-faux arrière.

La même limite de charge de 60 % s'applique également lorsqu'il est monté sur tout autre véhicule de loisir motorisé* dont le porte-à-faux arrière dépasse 230 cm, mesuré du centre de l'essieu arrière au point arrière le plus éloigné du véhicule.

AVERTISSEMENT : ce porte-vélos n'est pas compatible avec les remorques/

caravanes, les sellettes ou tout dispositif d'attelage monté sur pare-chocs.

* « Véhicule de loisir motorisé » tel que défini dans l'article 49 CFR 571.3(c), « Motor home », National Highway Traffic Safety Administration, U.S. Department of Transportation.

ES

La carga máxima permitida de este portaequipajes no debe superar el 60 % de su capacidad nominal (es decir, una reducción de carga total del 40 %) cuando se monta en:

- furgonetas de carga,
 - furgonetas de pasajeros,
 - conversiones de furgonetas,
- independientemente de la longitud del voladizo trasero.

La misma limitación de carga del 60 % también se aplica cuando se monta en cualquiera otra autocaravana* motorizada con un voladizo trasero superior a 230 cm (7,5 pies), medido desde el centro del eje trasero hasta el punto trasero más distante del vehículo.

ADVERTENCIA: Este portaequipajes no es compatible con remolques/caravanas, quintas ruedas ni ningún receptor de enganche montado en el parachoques.

*"Autocaravana motorizada" como se define en 49 CFR 571.3(c), "Autocaravana", Administración Nacional de Seguridad Vial en Carreteras, Departamento de Transporte de Estados Unidos.

PT

A carga máxima permitida neste suporte não deve exceder 60% da capacidade nominal (ou seja, redução total de carga de 40%) quando montada em:

- vans de carga,
 - vans de passageiros,
 - conversões de vans,
- independentemente do comprimento do balanço traseiro.

A mesma limitação de carga de 60% também se aplica quando montado em qualquer outro RV motorizado* com balanço traseiro superior a 230 cm (7,5 ft) medido do centro do eixo até o ponto traseiro mais distante do veículo.

AVISO: este suporte não é compatível com trailers de viagem/caravans, 5ª roda, ou qualquer receptor de engate destacável montado no para-choque.

*"RV motorizado" conforme definido em 49 CFR 571,3(c), "Motor home", National Highway Traffic Safety Administration, Departamento de Transportes dos EUA.

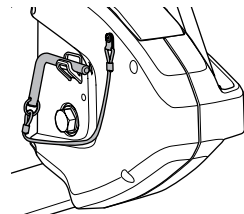
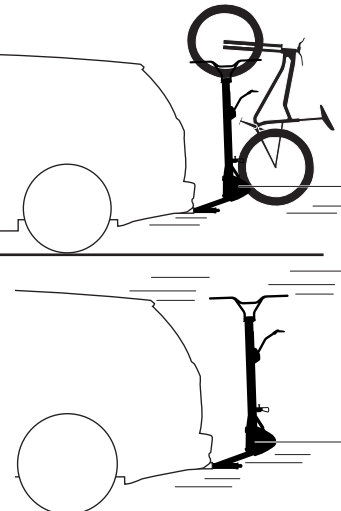
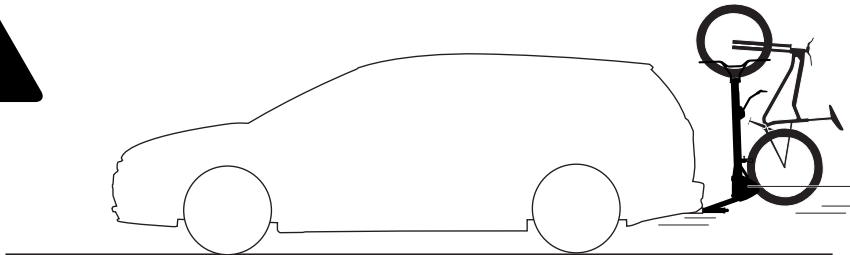
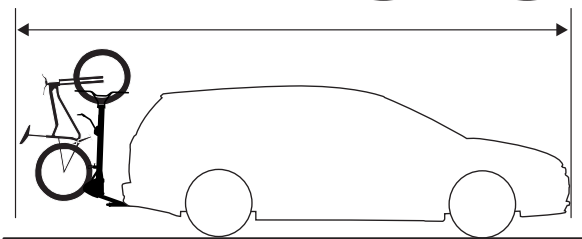
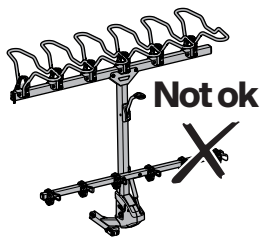
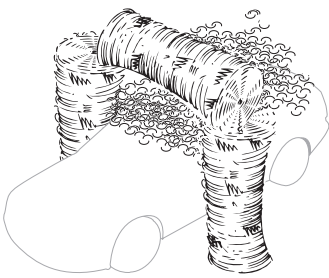

Not ok
X

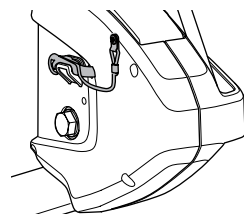

ok
✓



87lbs.
(39.5 kg)

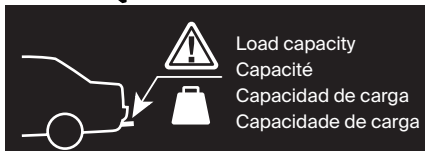

Max 55 lbs.
(25 kg)

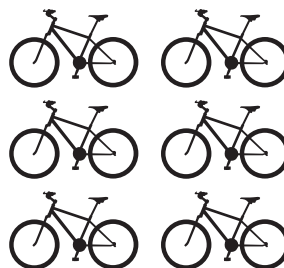

Max 250 lbs.
(113 kg)



ok
✓



Not ok
✗



Not ok
✗

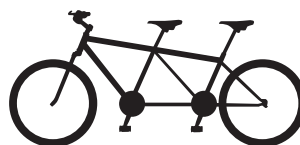

Not ok
✗



Not ok
✗

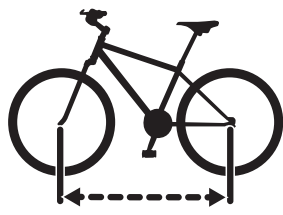

53" max
wheelbase



24"-29" max



1"- 3" max

Thule ReVert 24"
wheel adapter
9020530



24" max

Thule ReVert fatbike
wheel basket
9020540

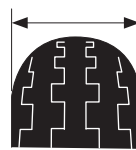

3"- 5" max

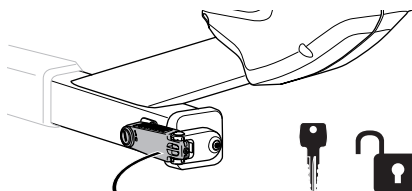

300 miles
500 km

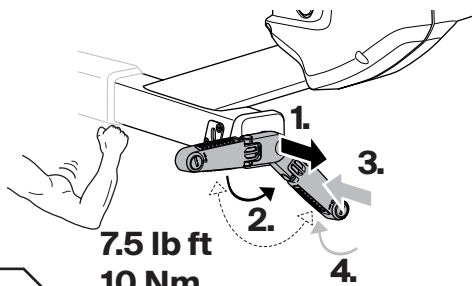

7.5 lb ft
10 Nm

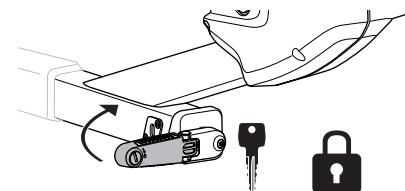

i

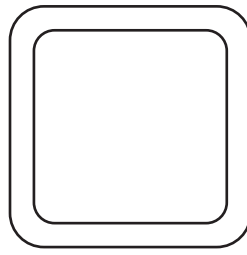
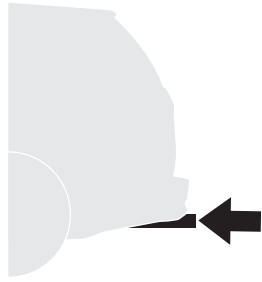

2"
51 mm

1

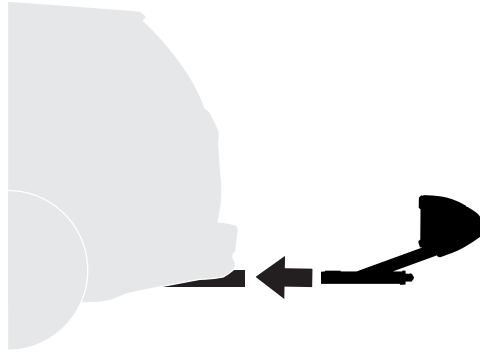

A

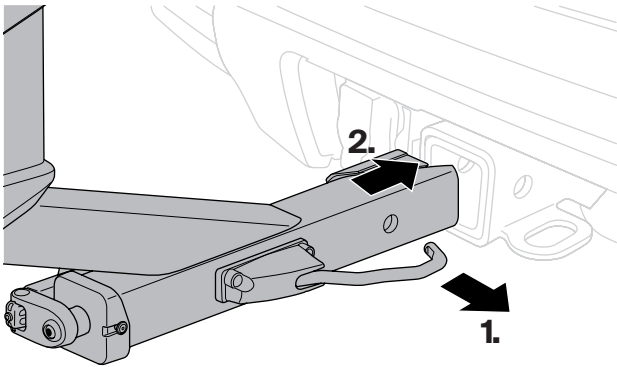

B

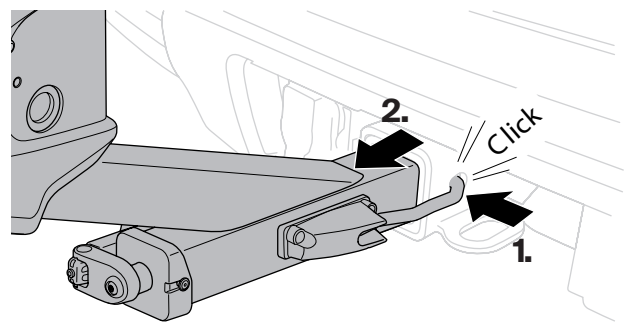

2

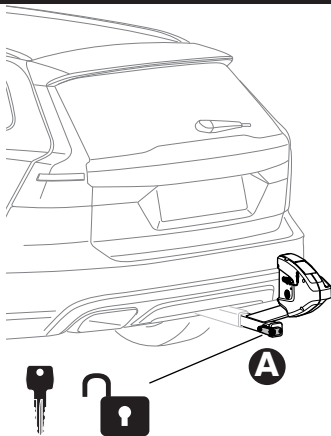

C

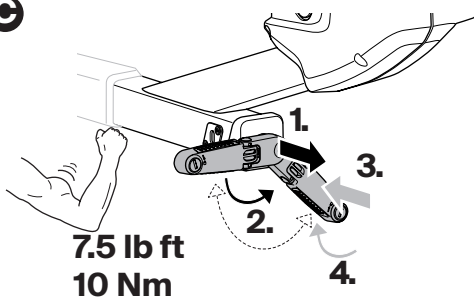

7.5 lb ft
10 Nm

B

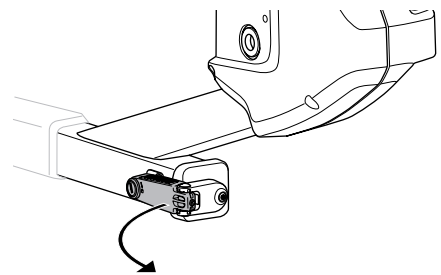

D

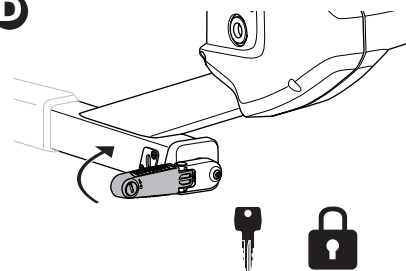

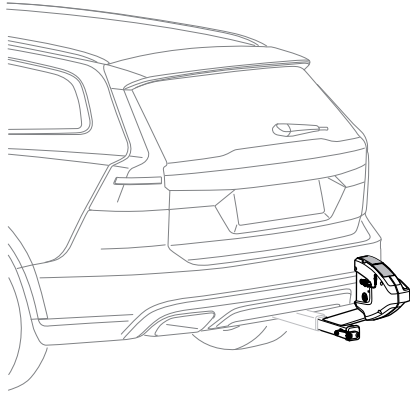

A

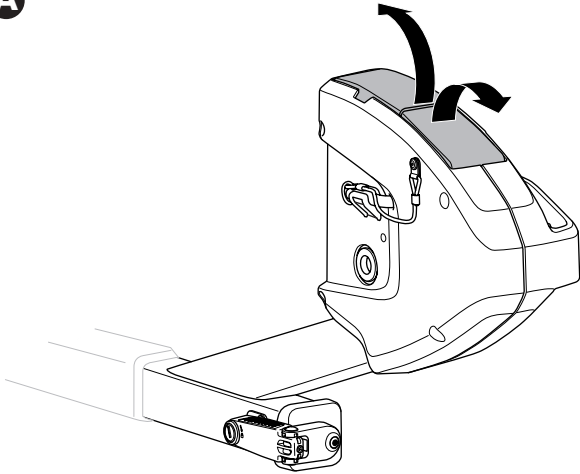

B

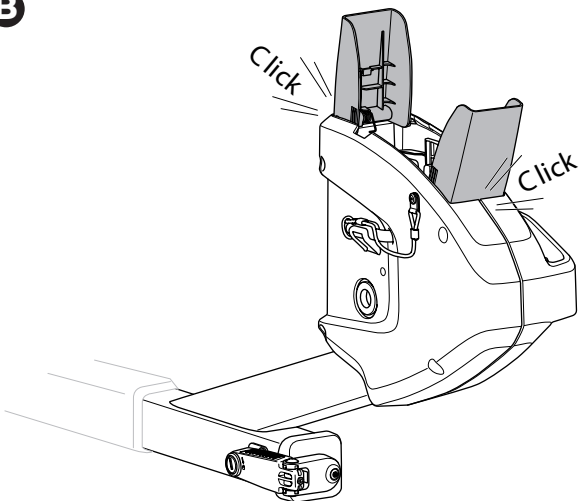

C

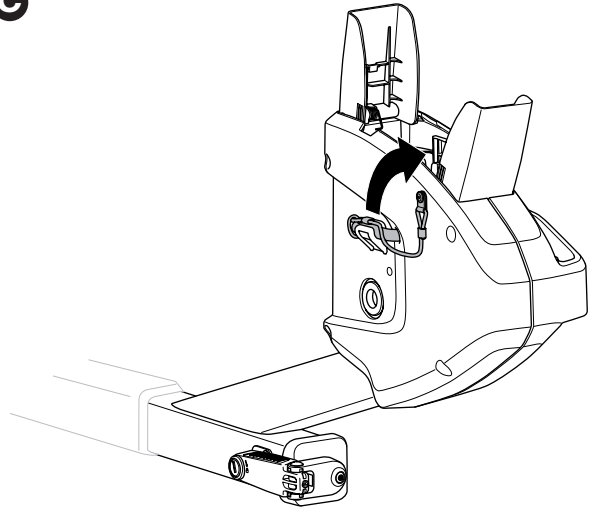

D

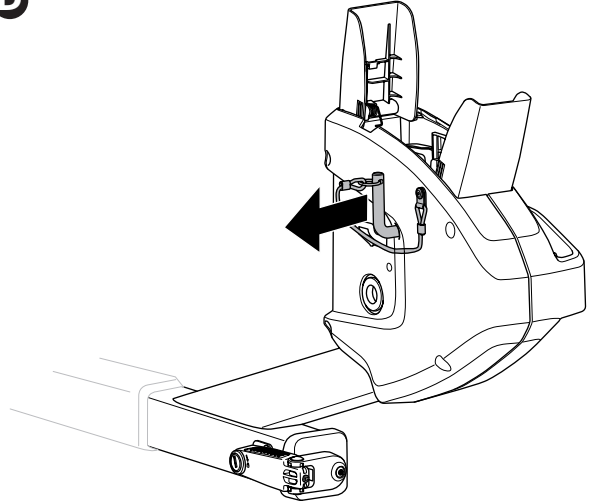

E

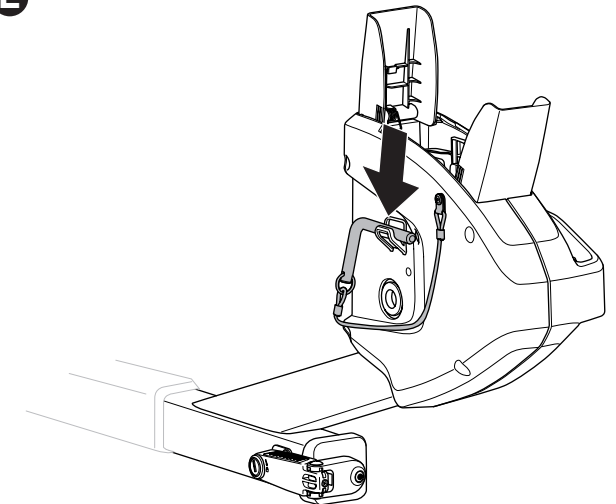

4

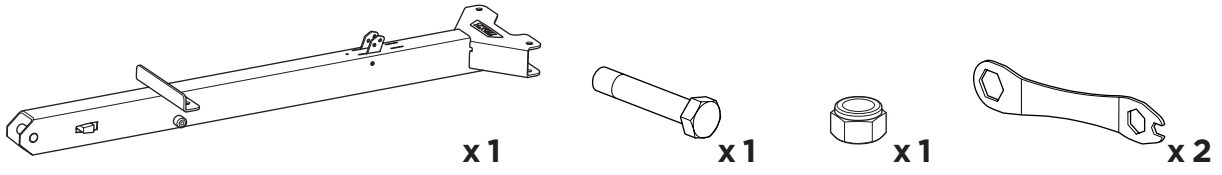

A

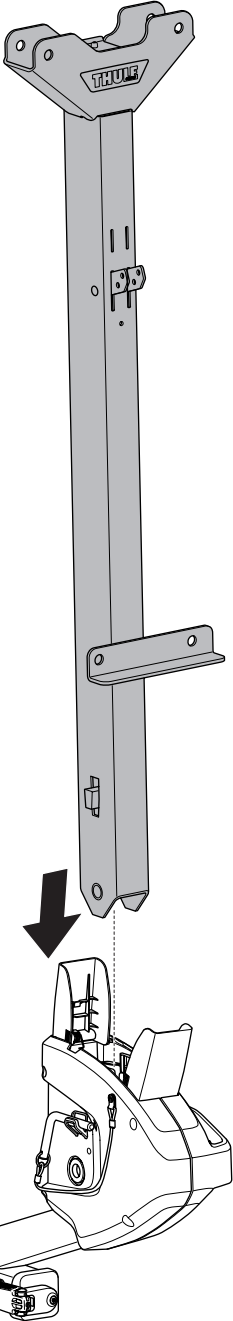

B

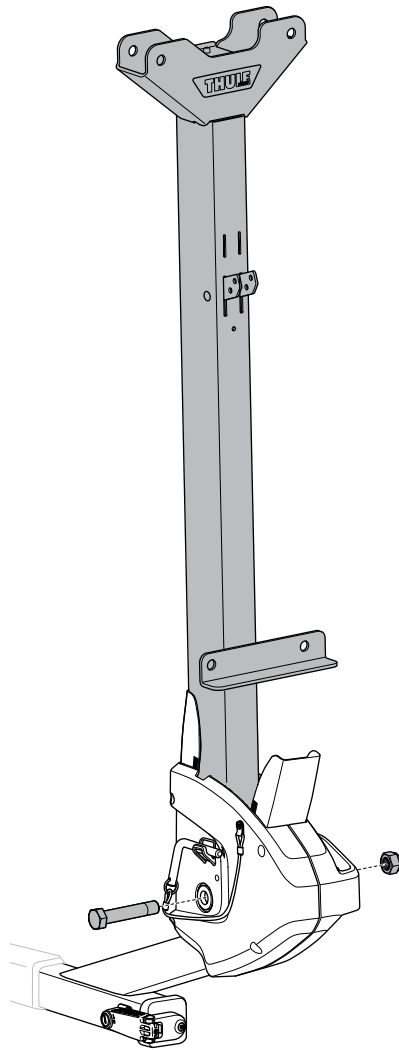

C

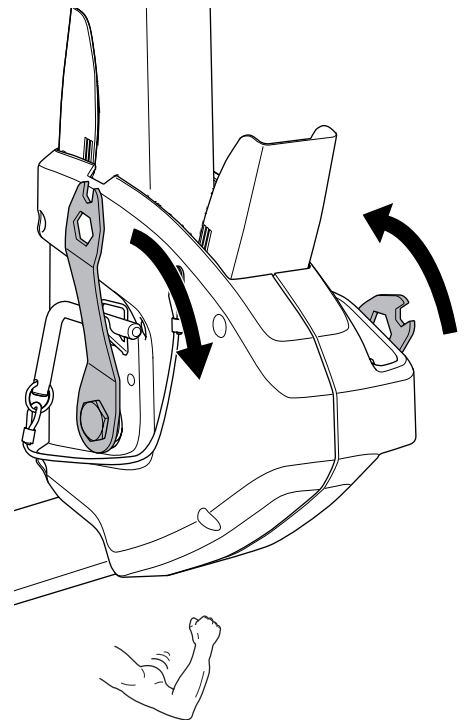

22.13 lb ft
30 Nm

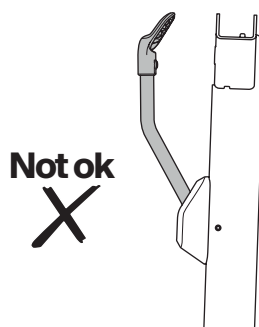
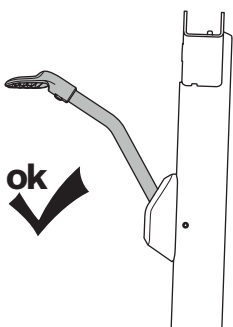
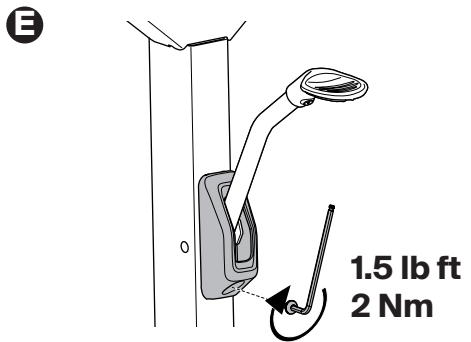
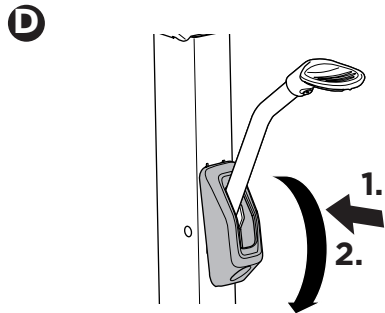
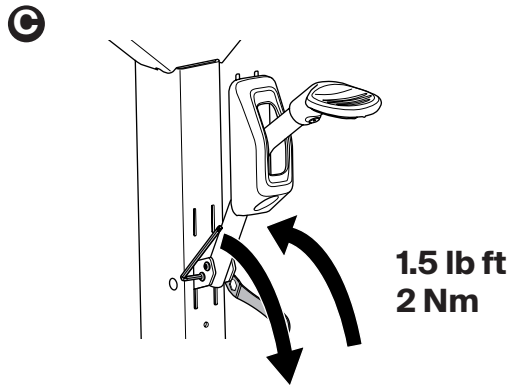
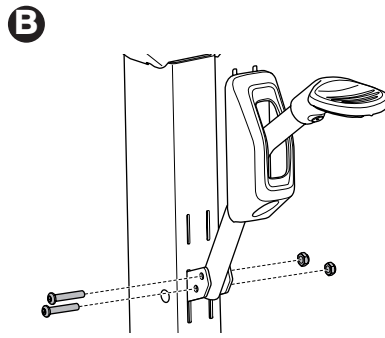
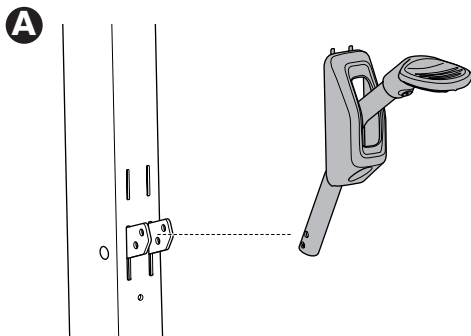
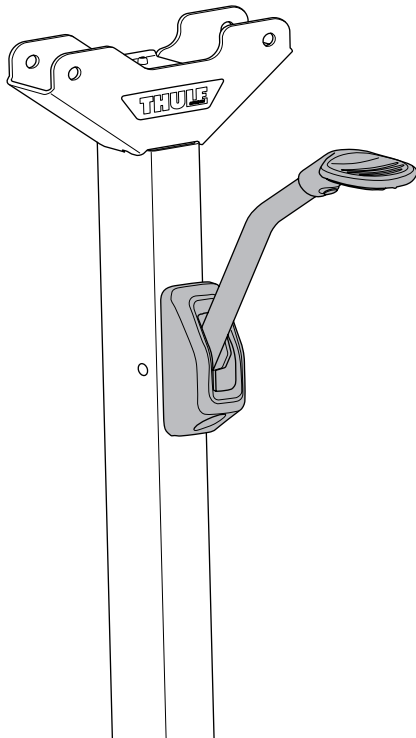
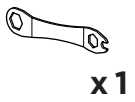
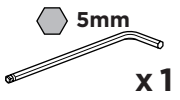
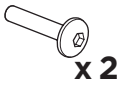
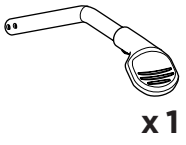
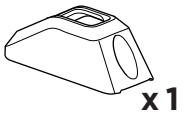

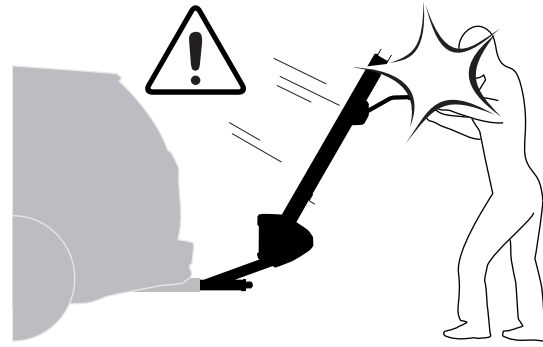

6

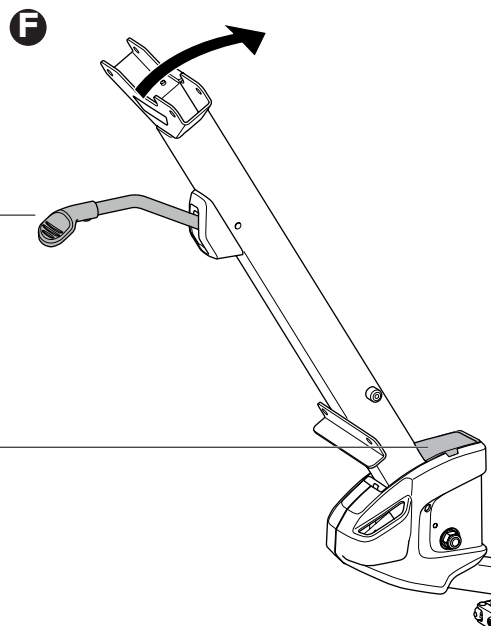
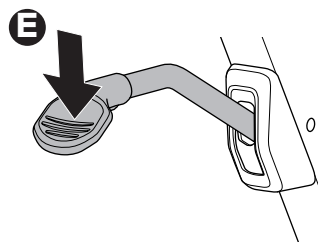
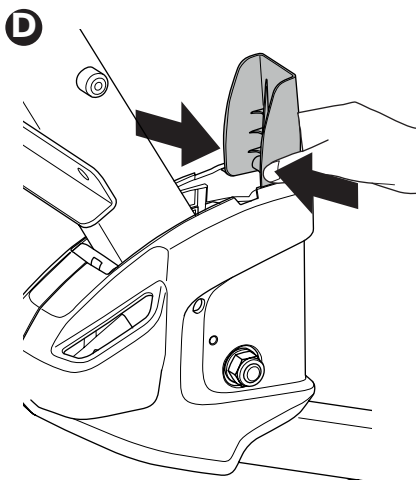
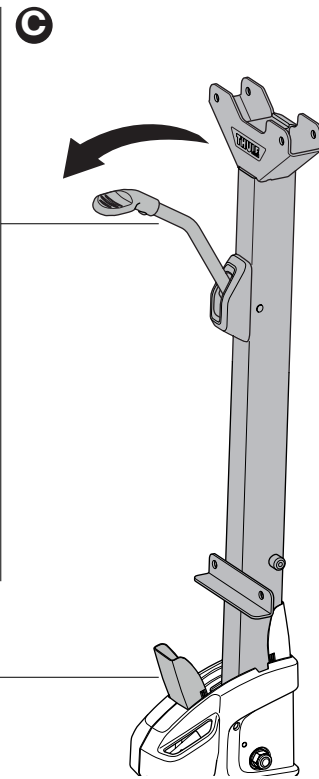
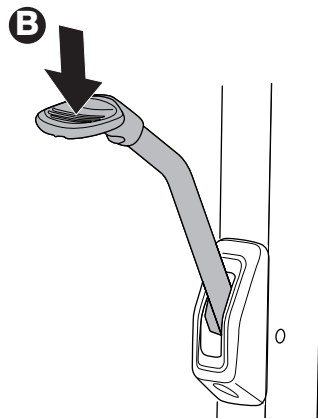
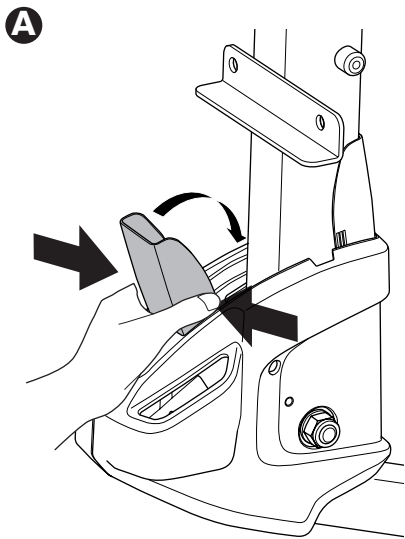

7

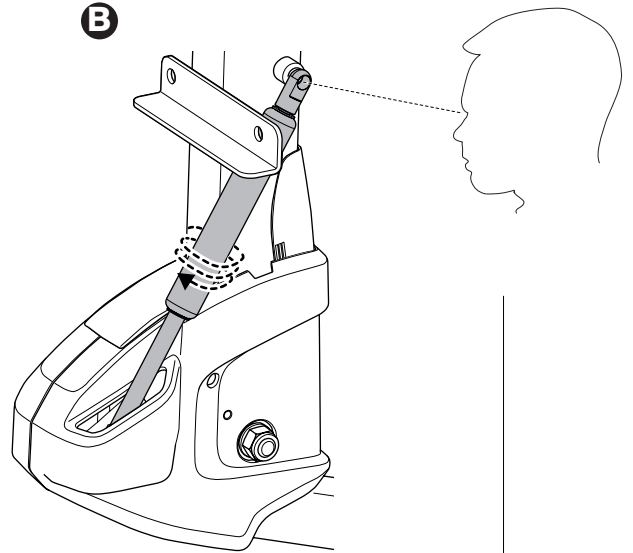
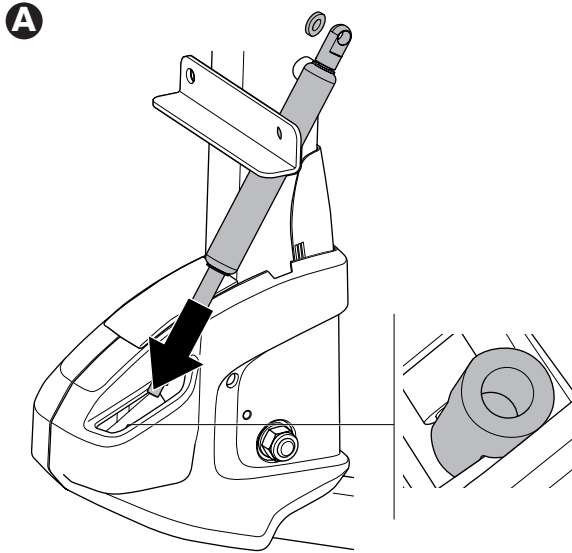
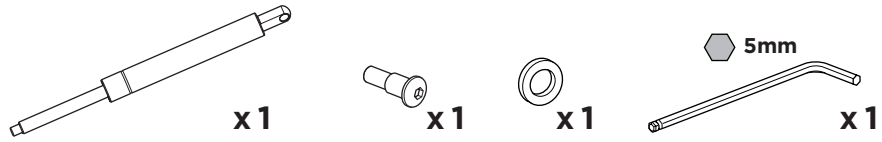

ok ✓

Not ok ✗

Not ok ✗

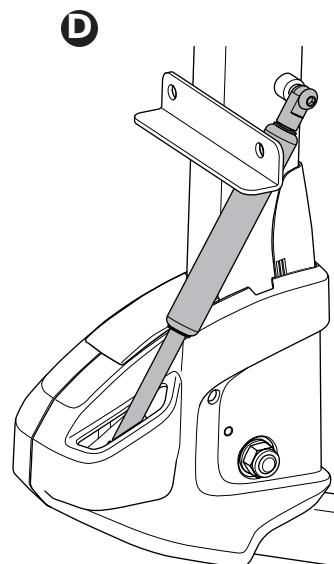
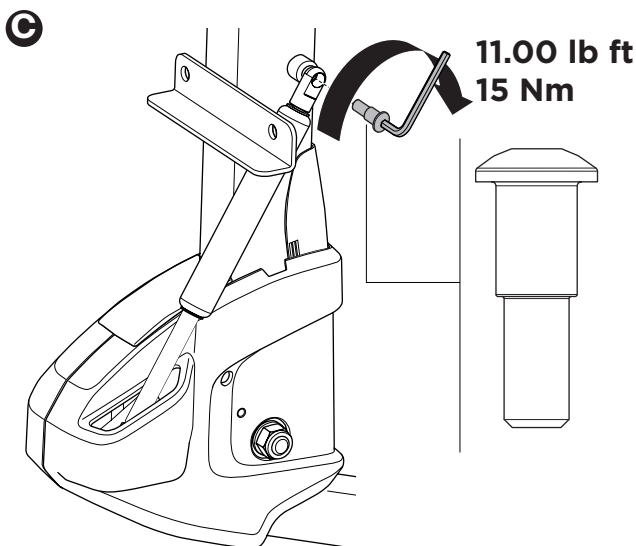
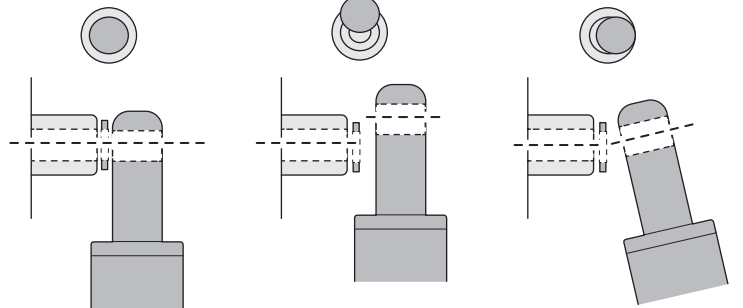

8

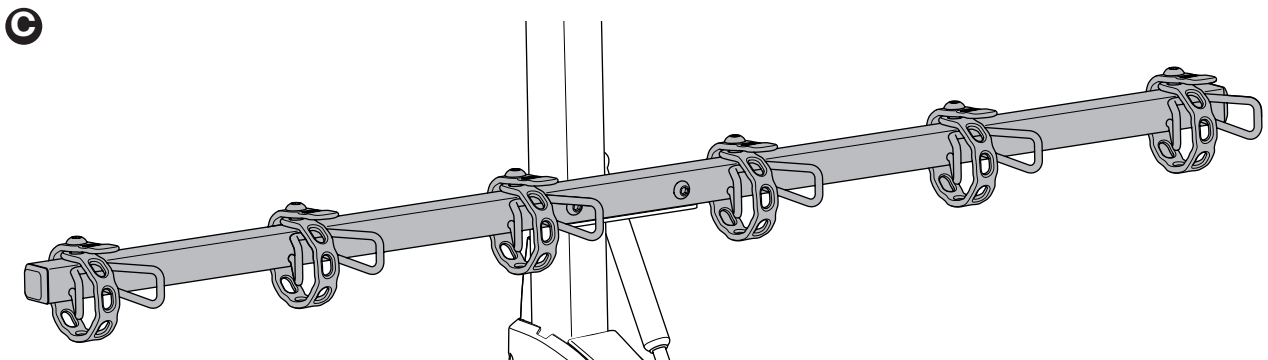
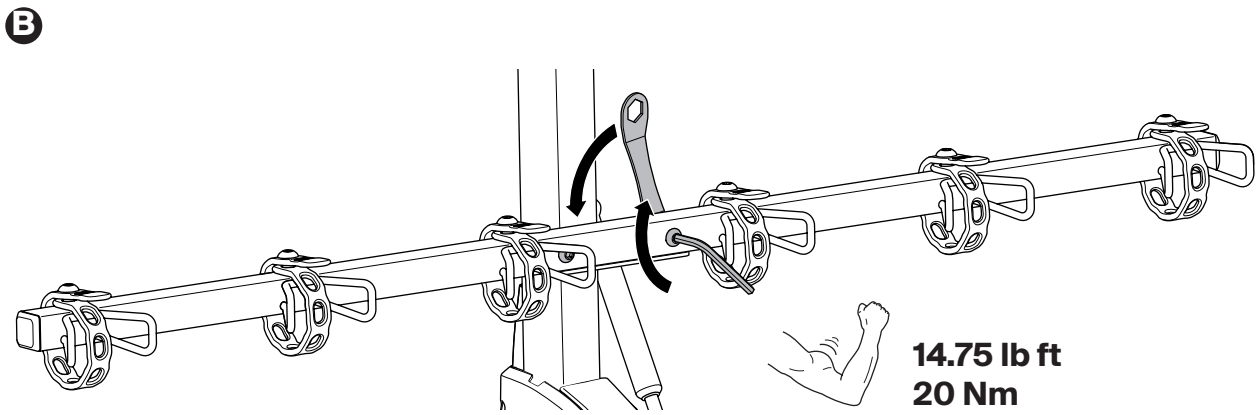
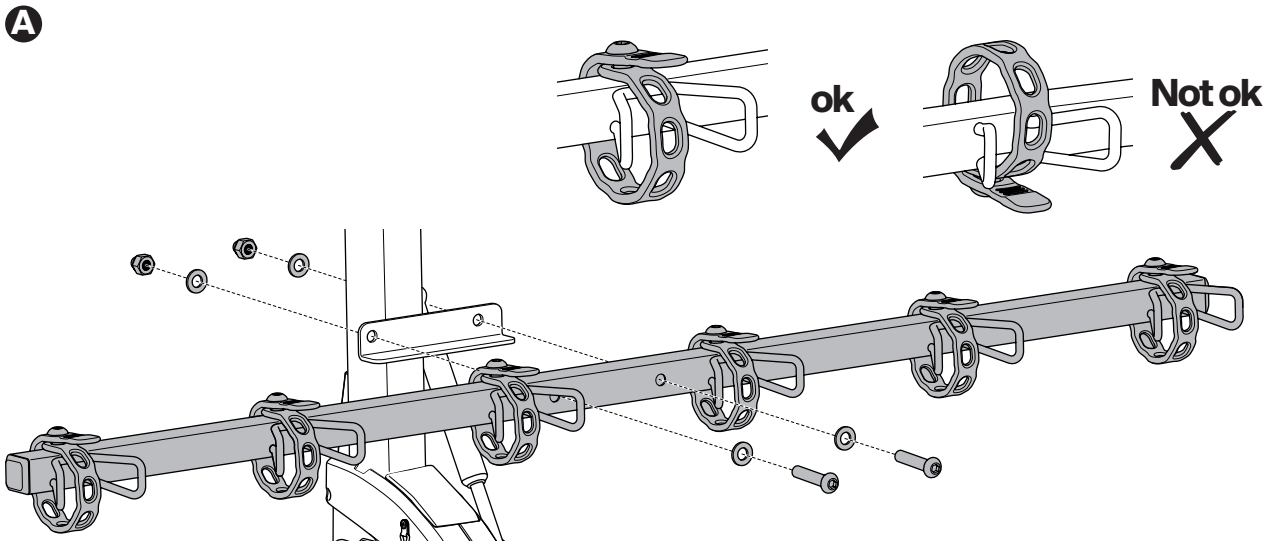
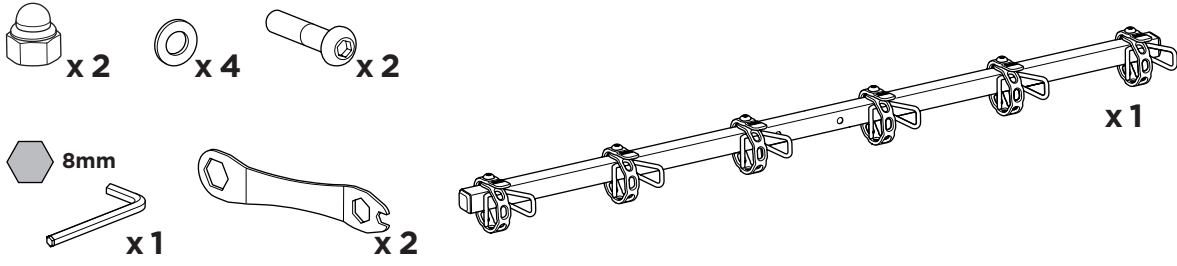

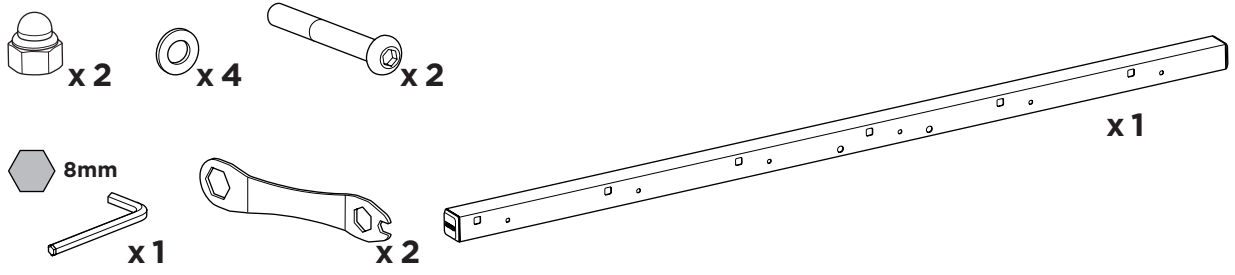

A

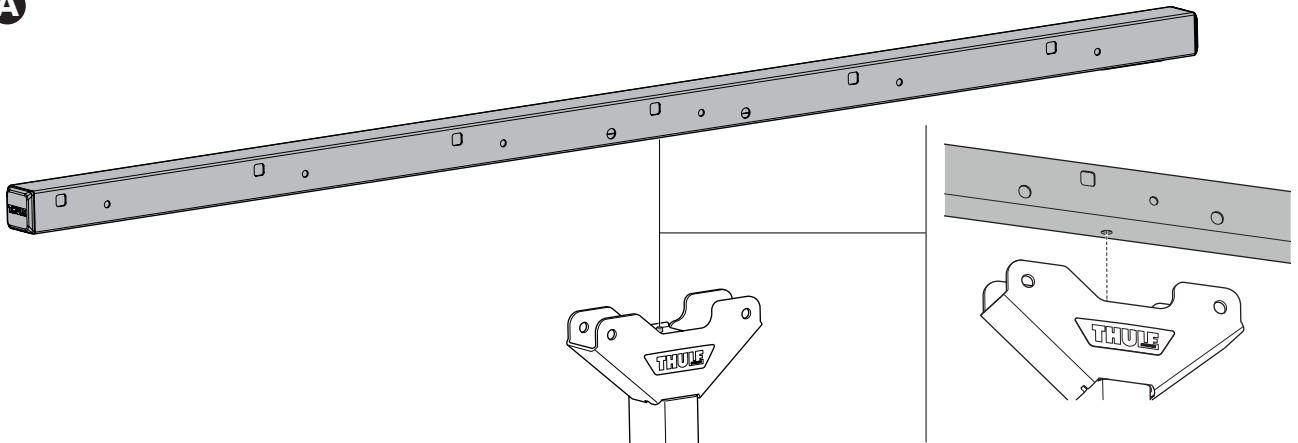

B

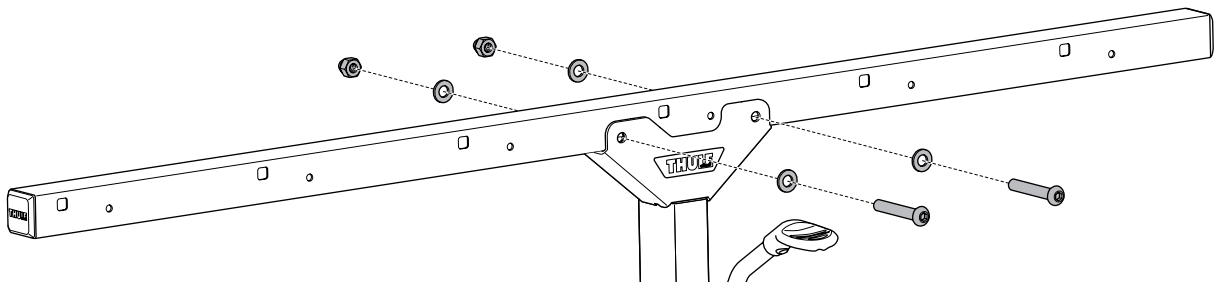

C

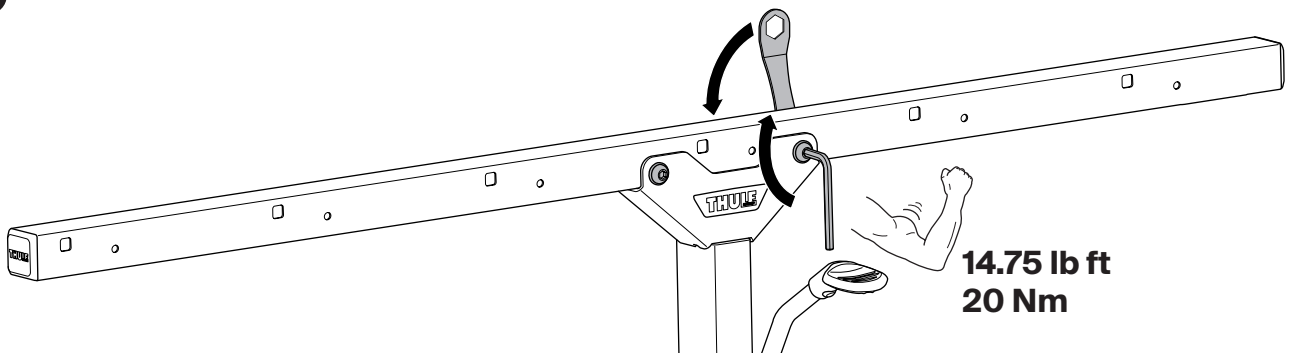

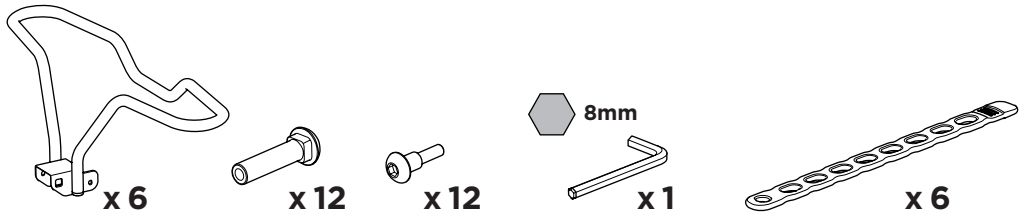

A

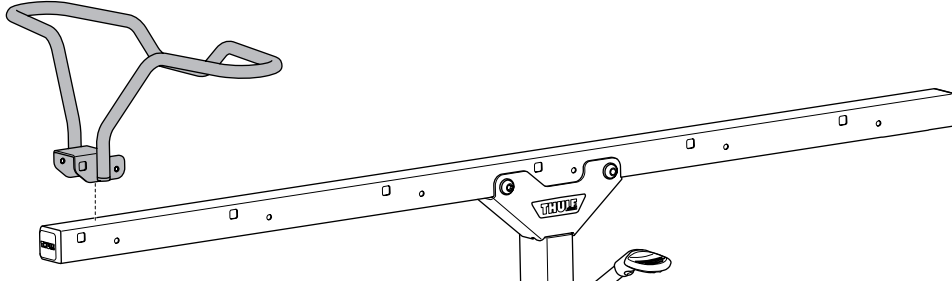

B

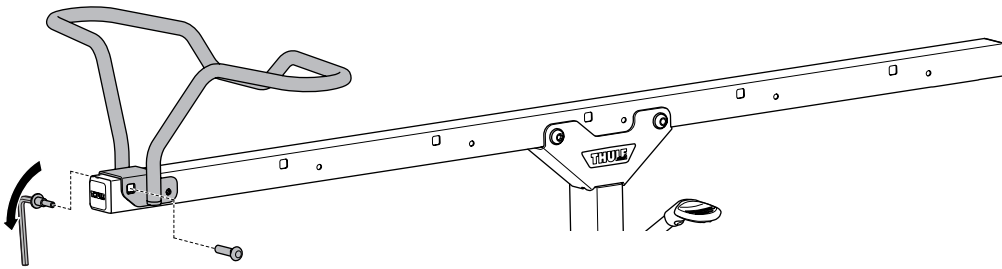

C

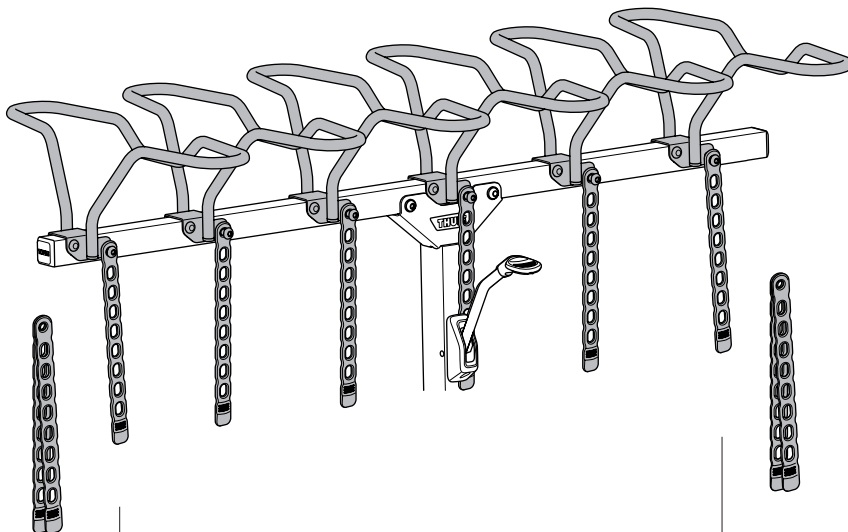
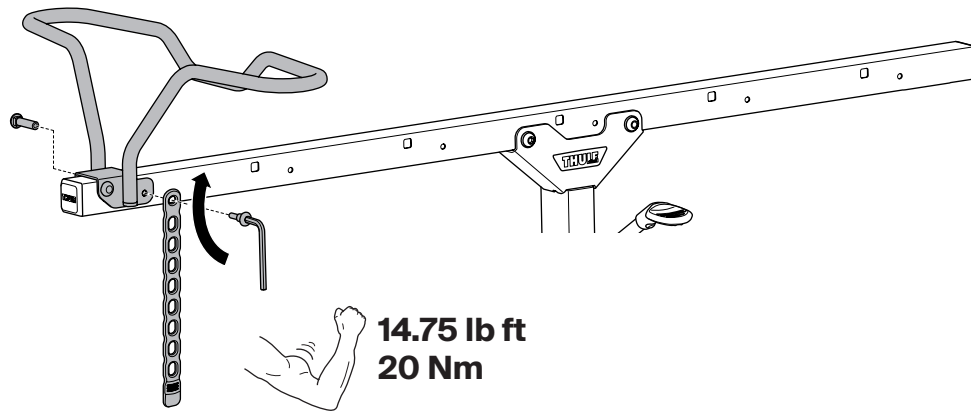

i

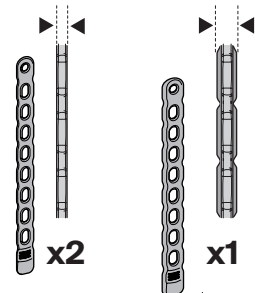

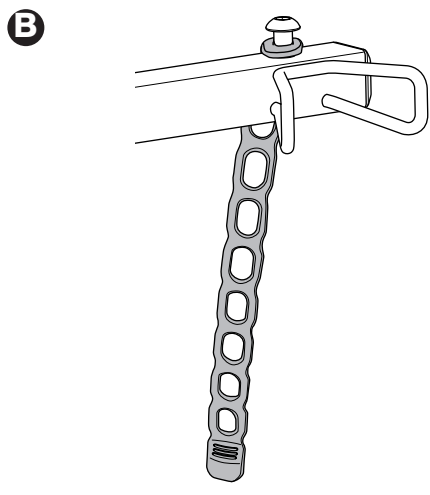
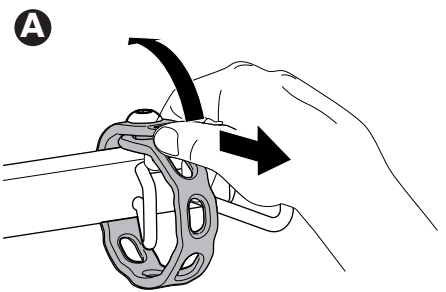
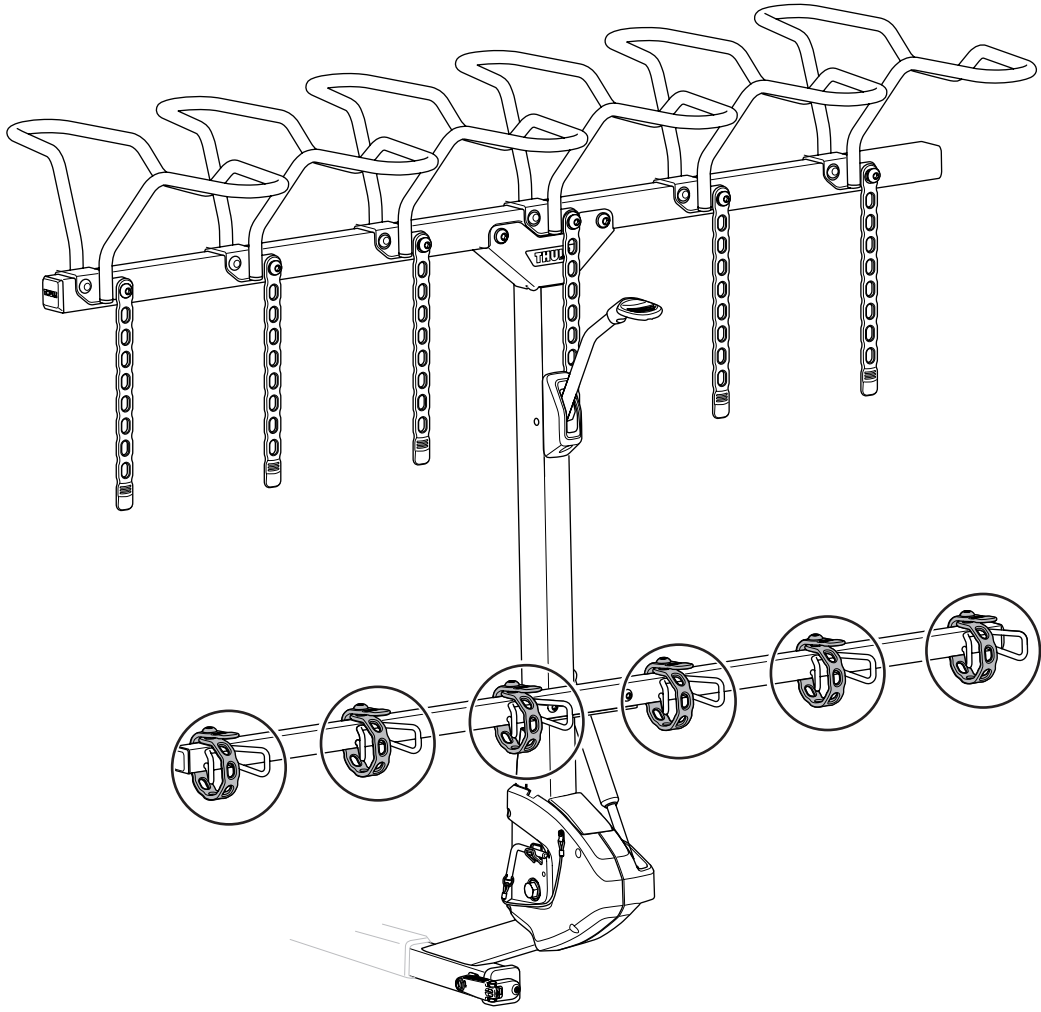

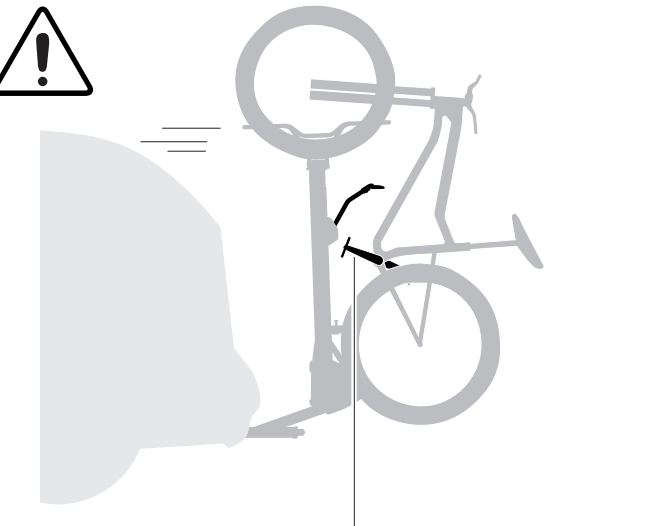
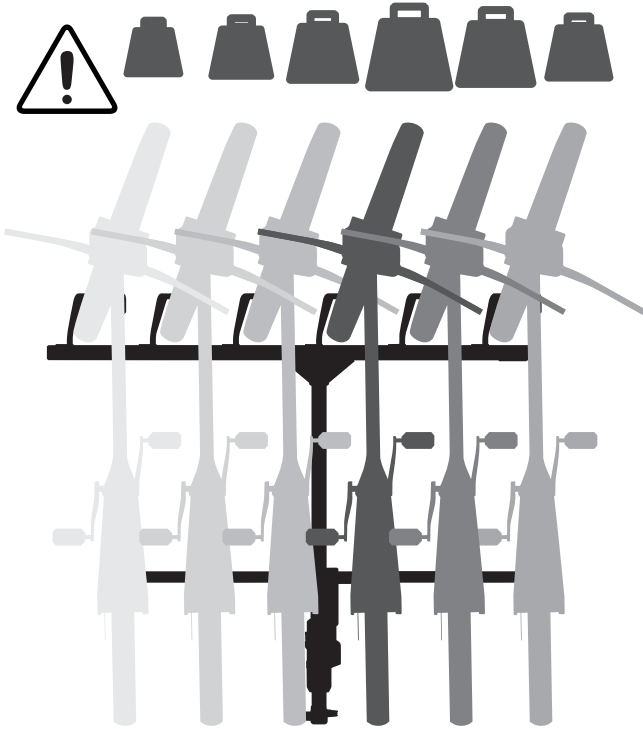
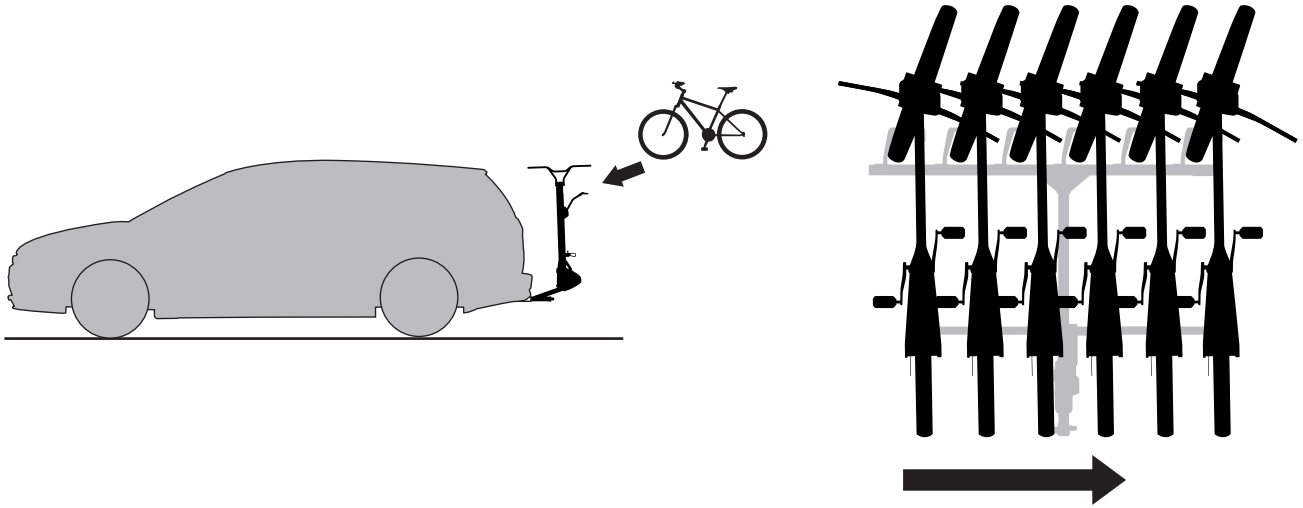

Not ok



ok

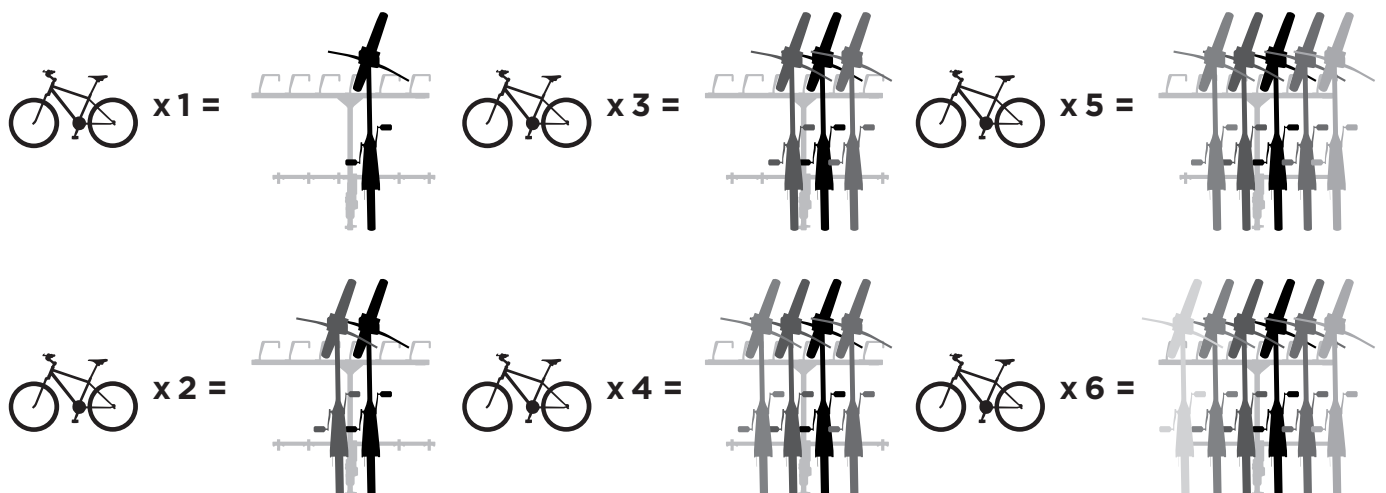

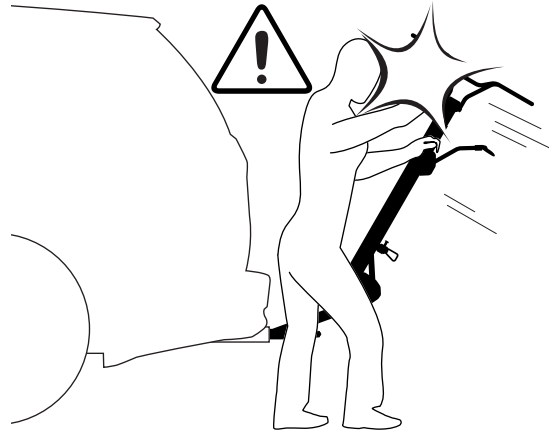
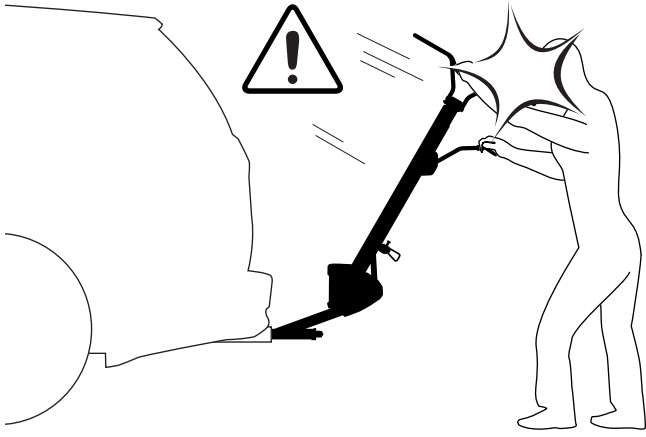

12

A

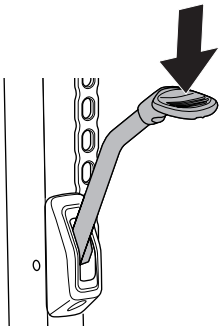

B

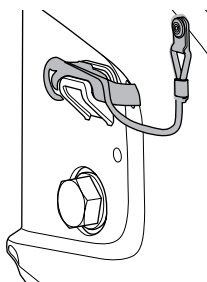
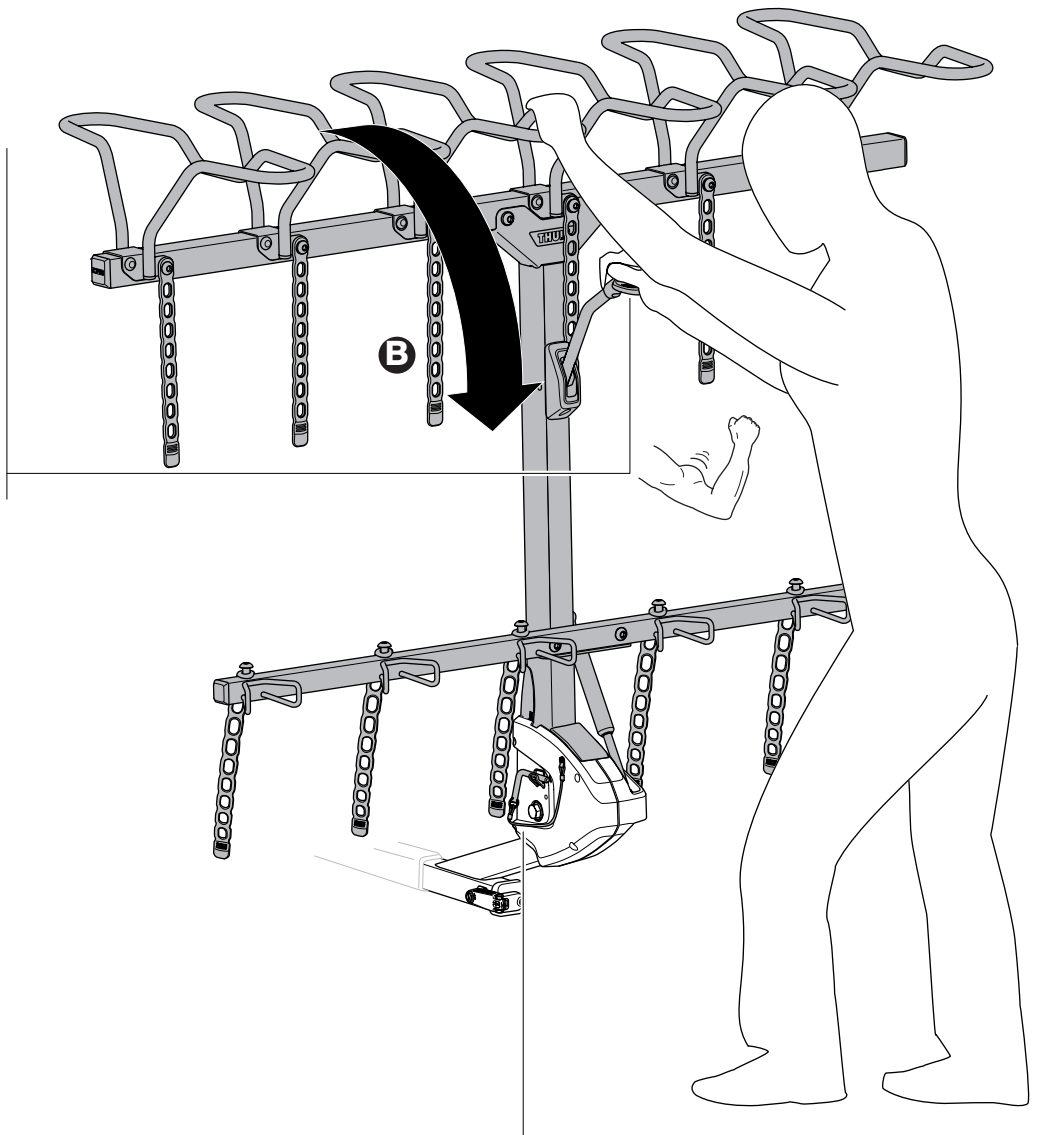

Not ok

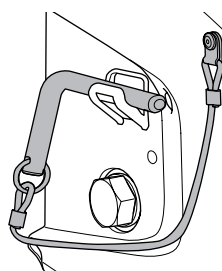

ok





Ⓒ

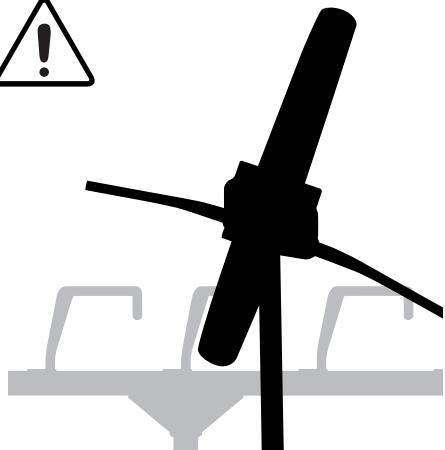
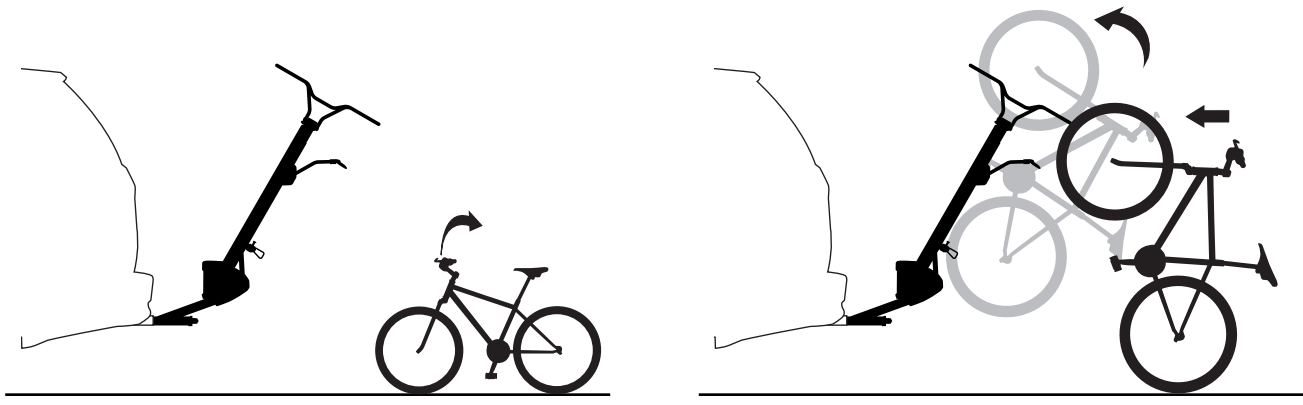
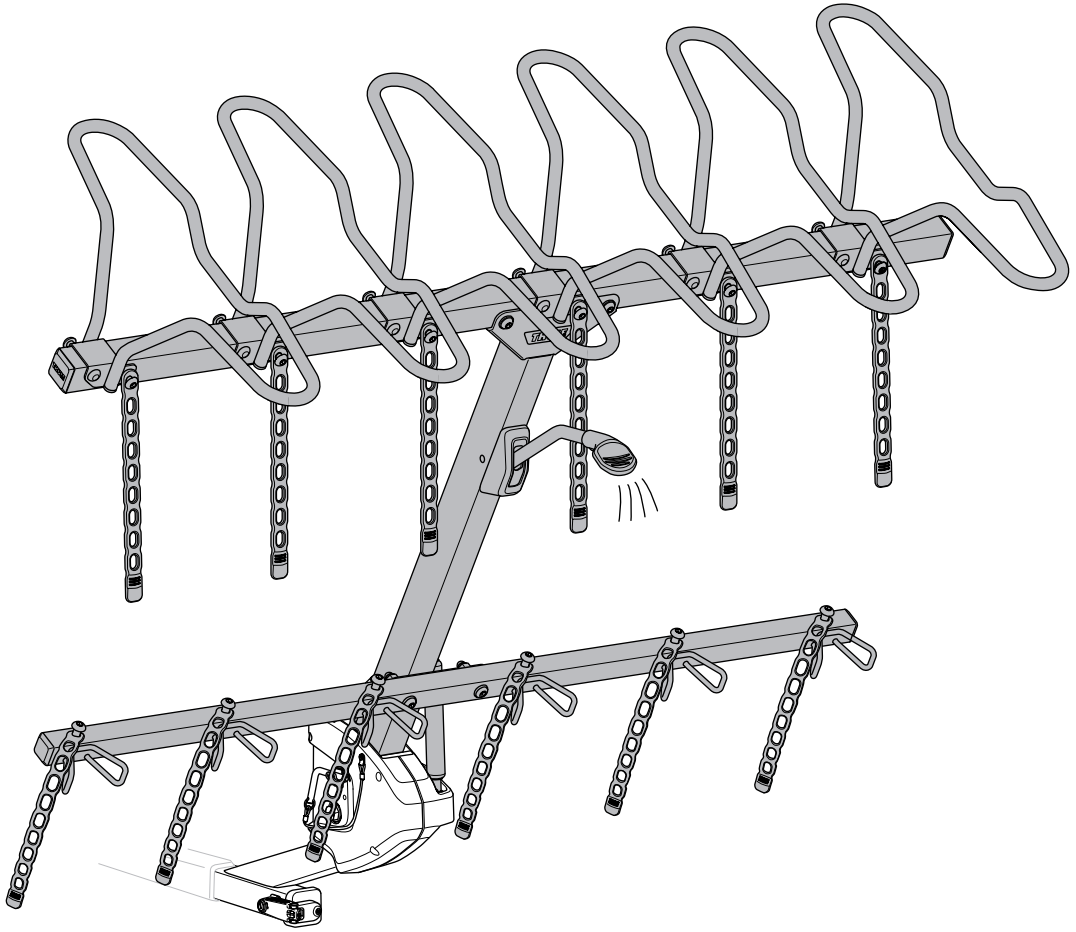

14

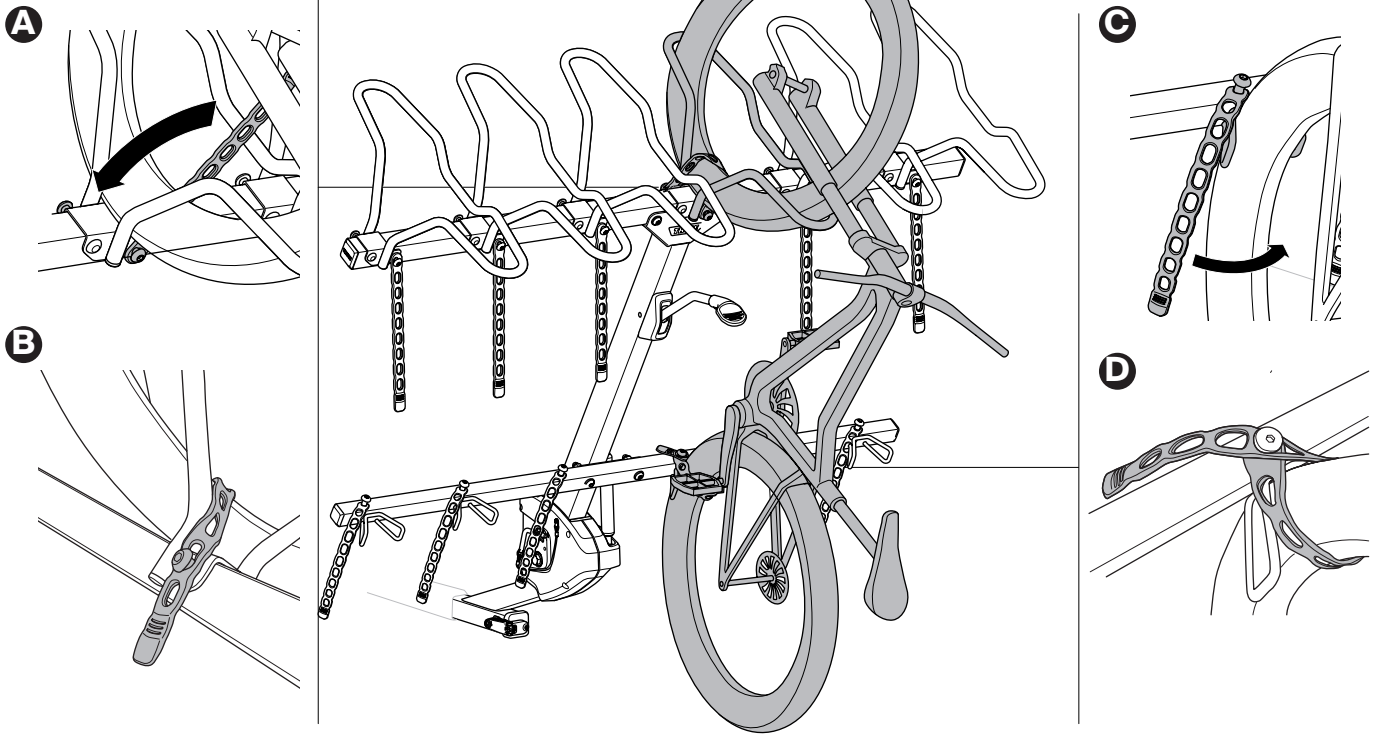

15

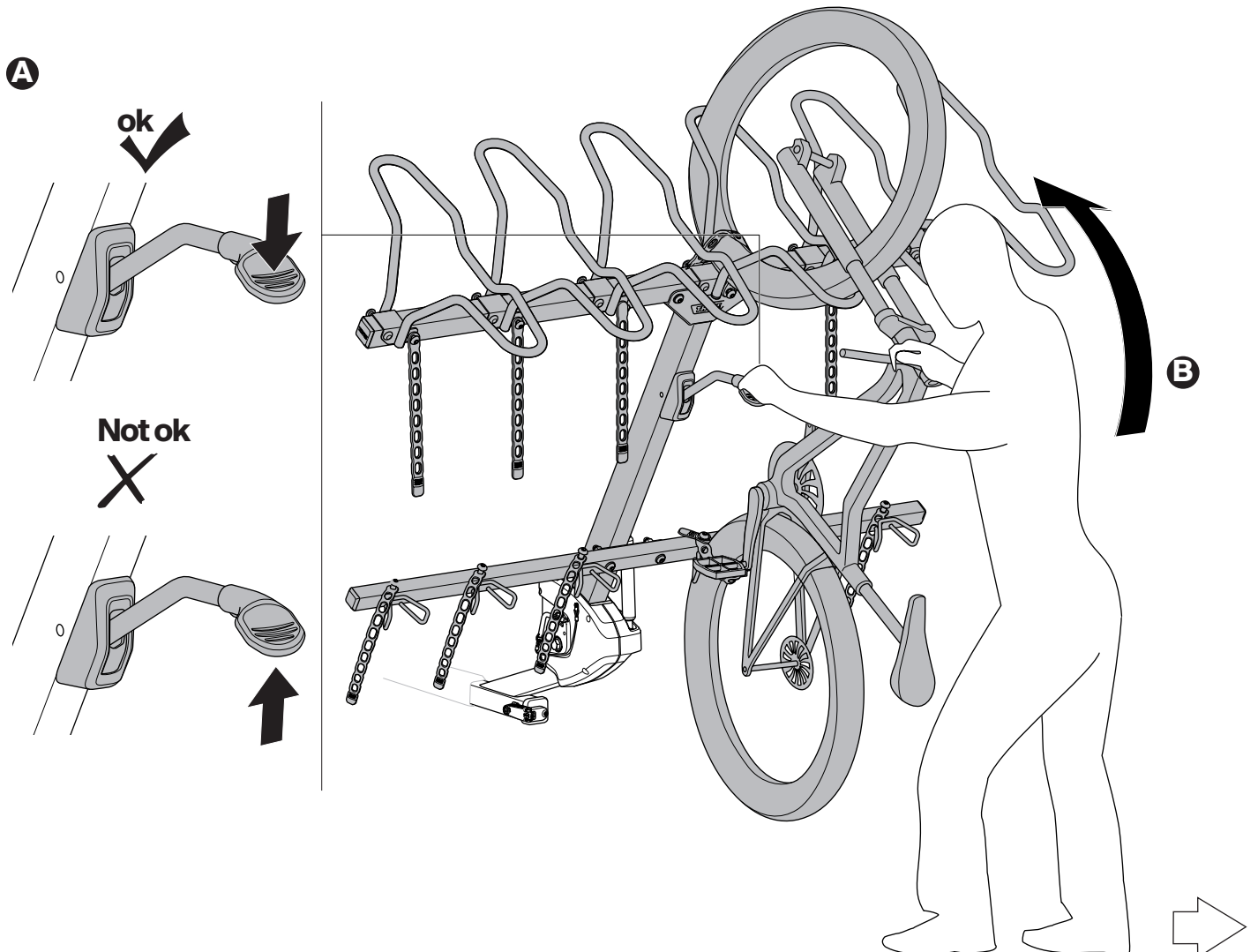

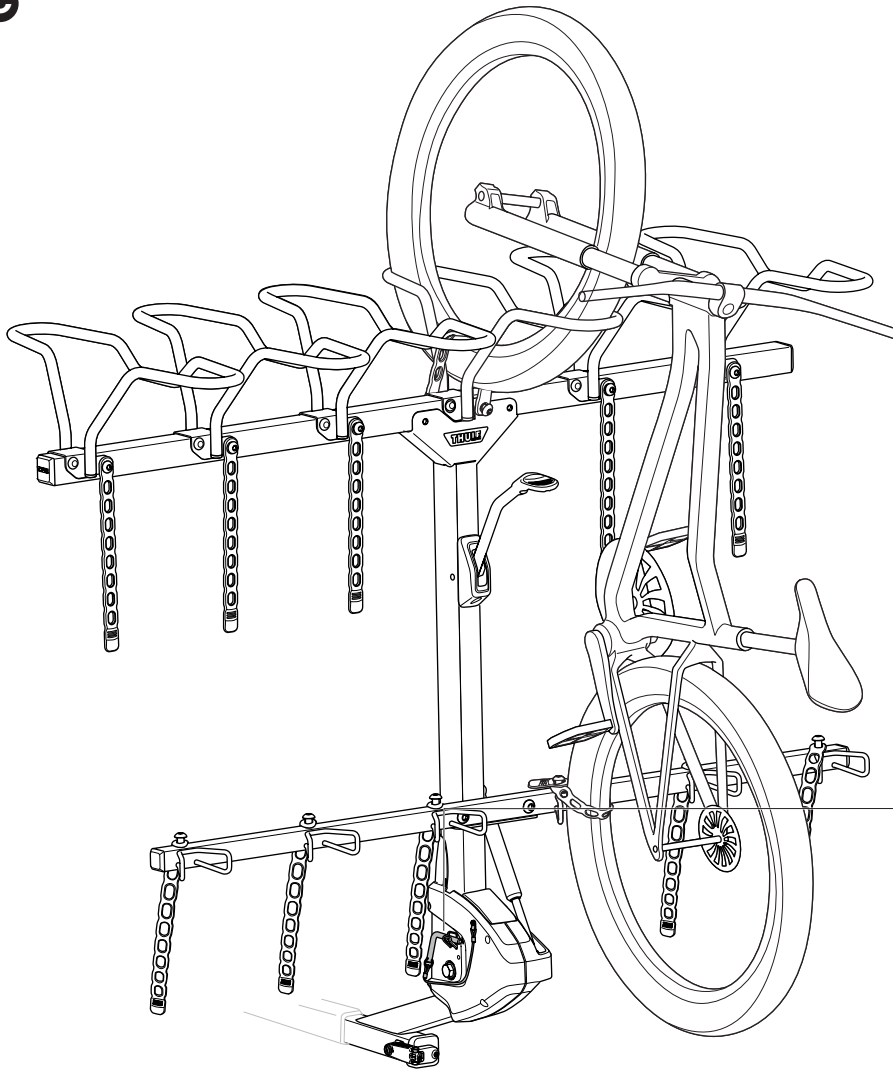
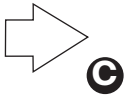

- 1.
- 2.
- 3.

i

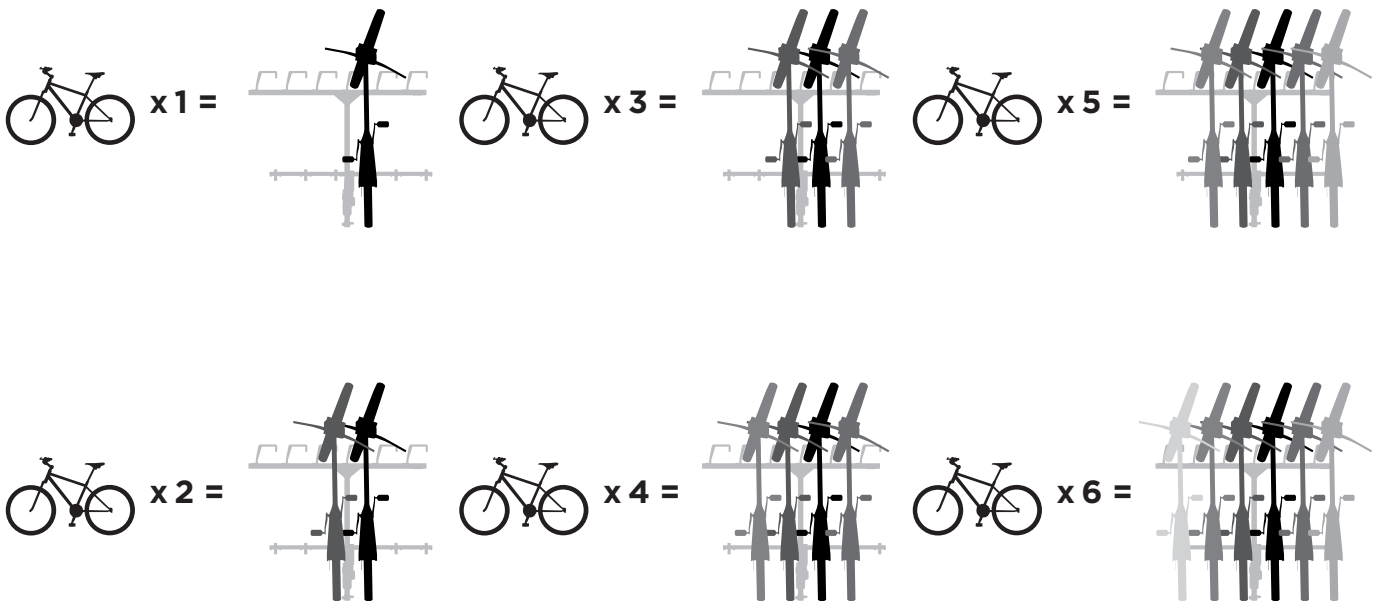

A

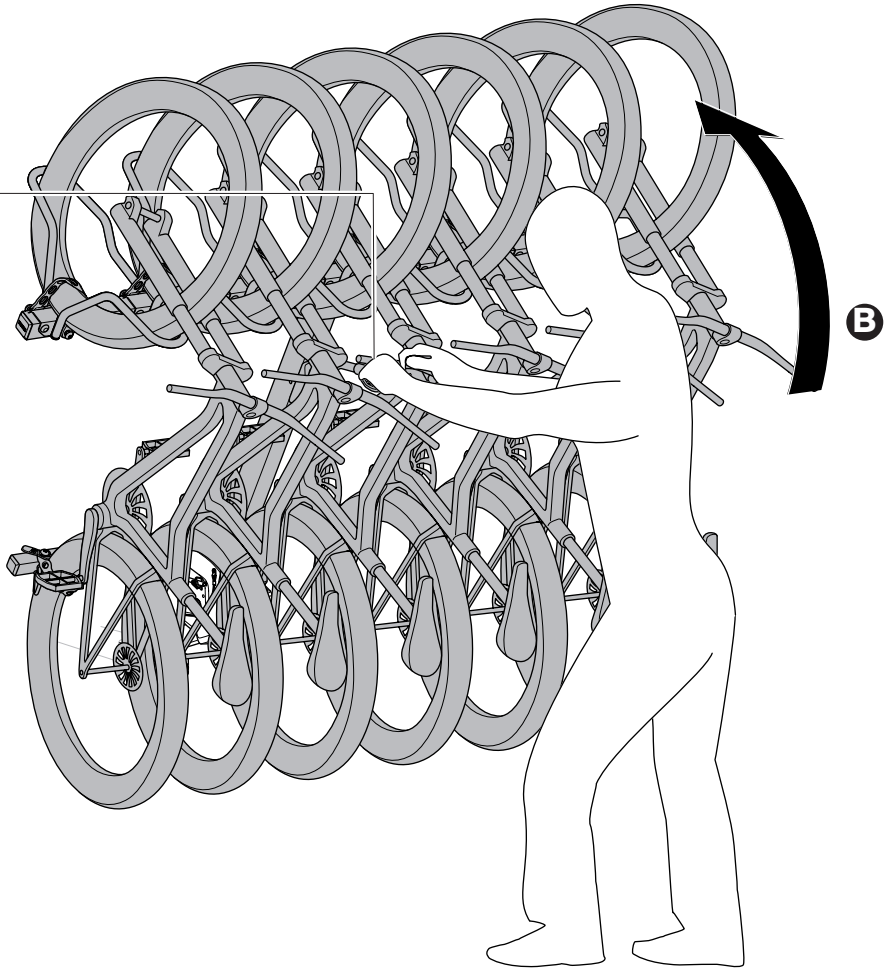

C

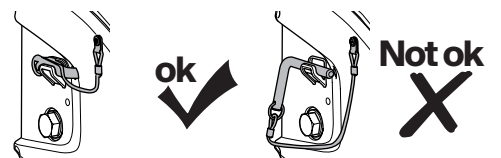
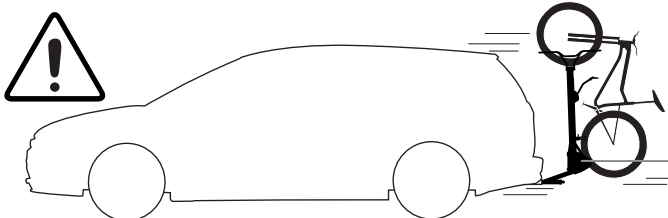
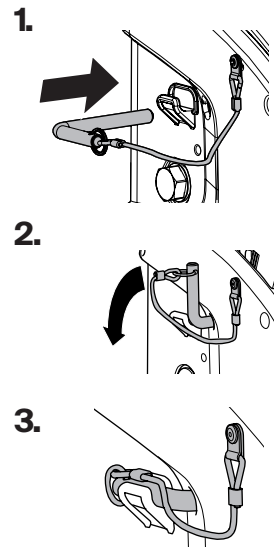
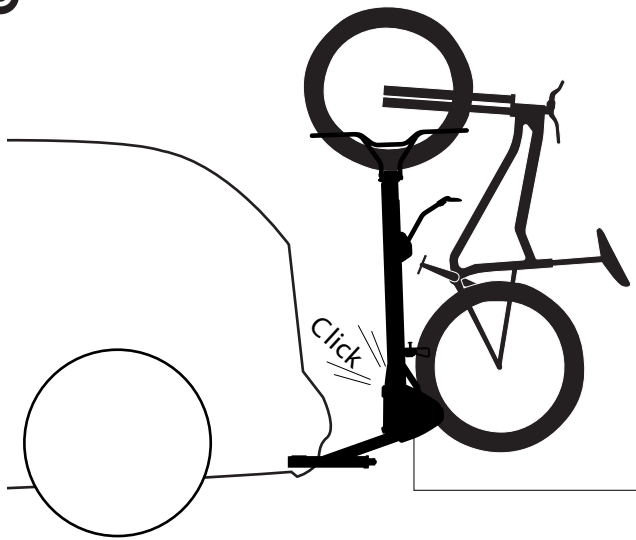

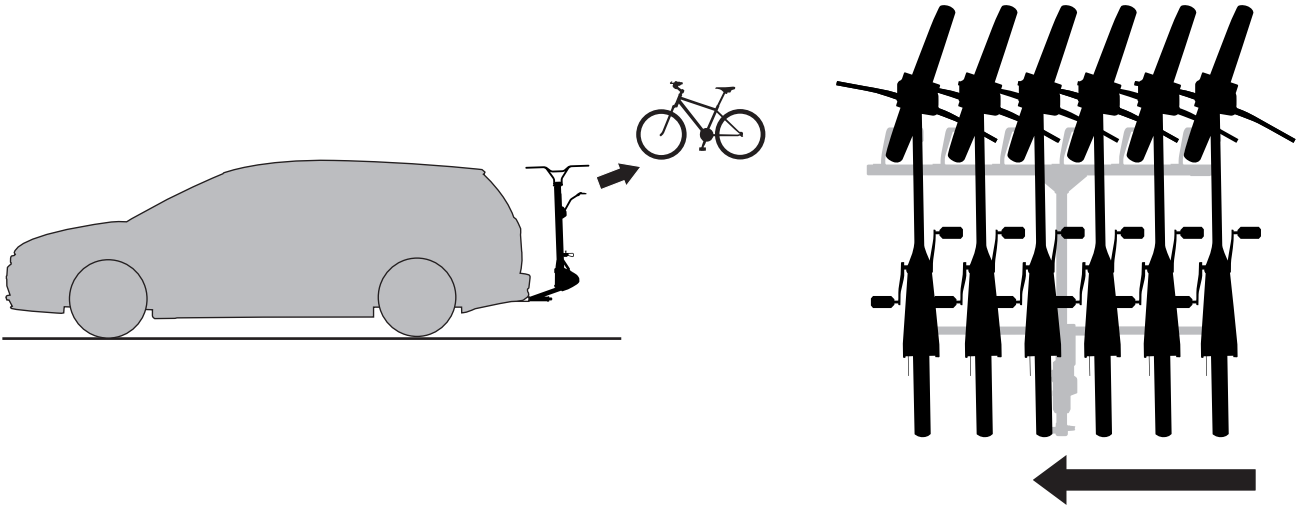

A

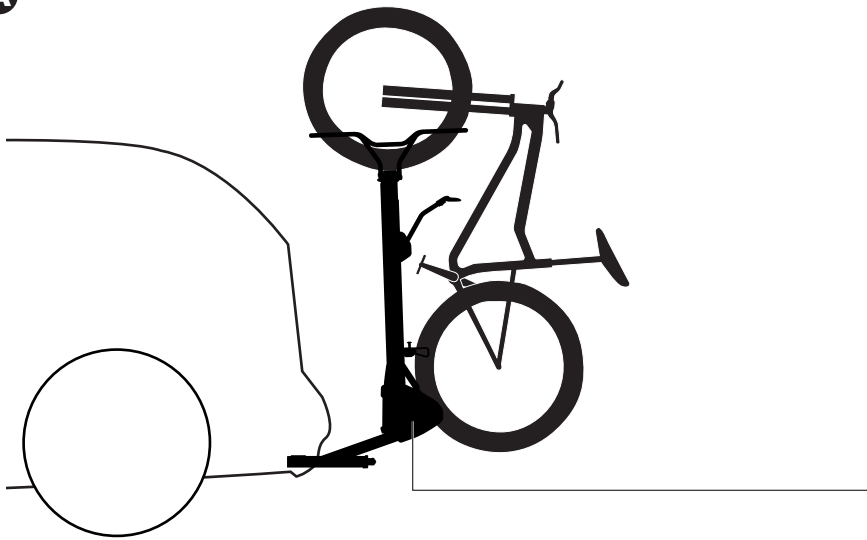

B

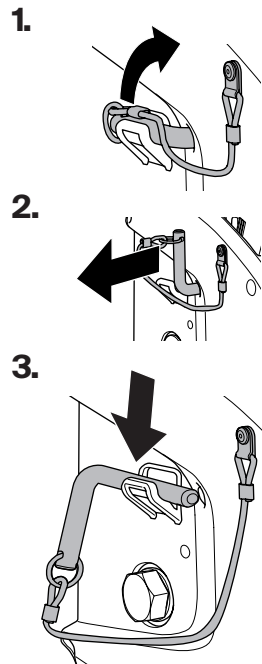

B

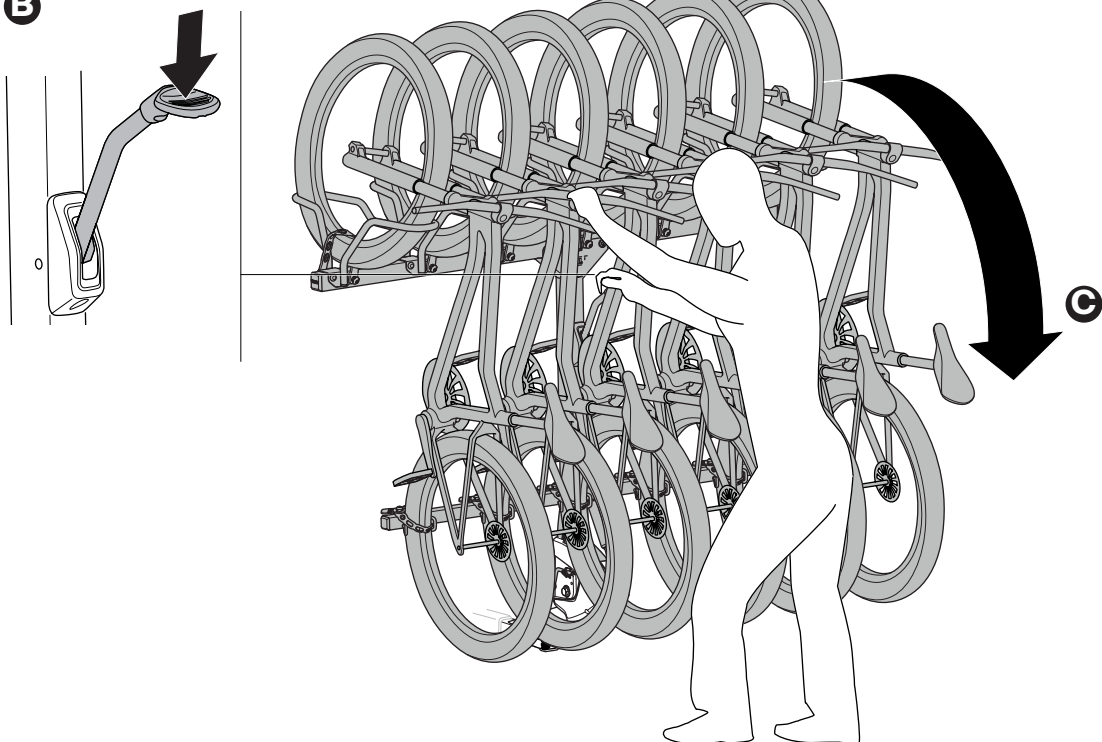

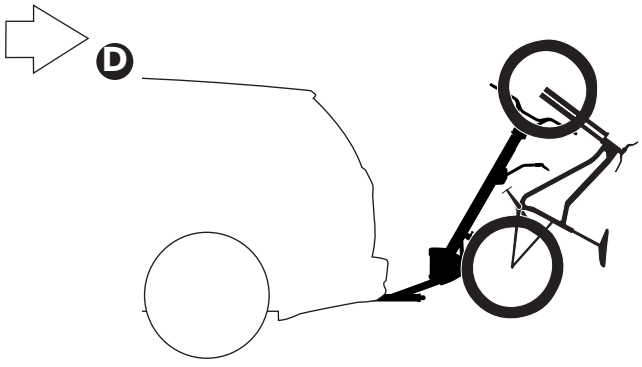

E

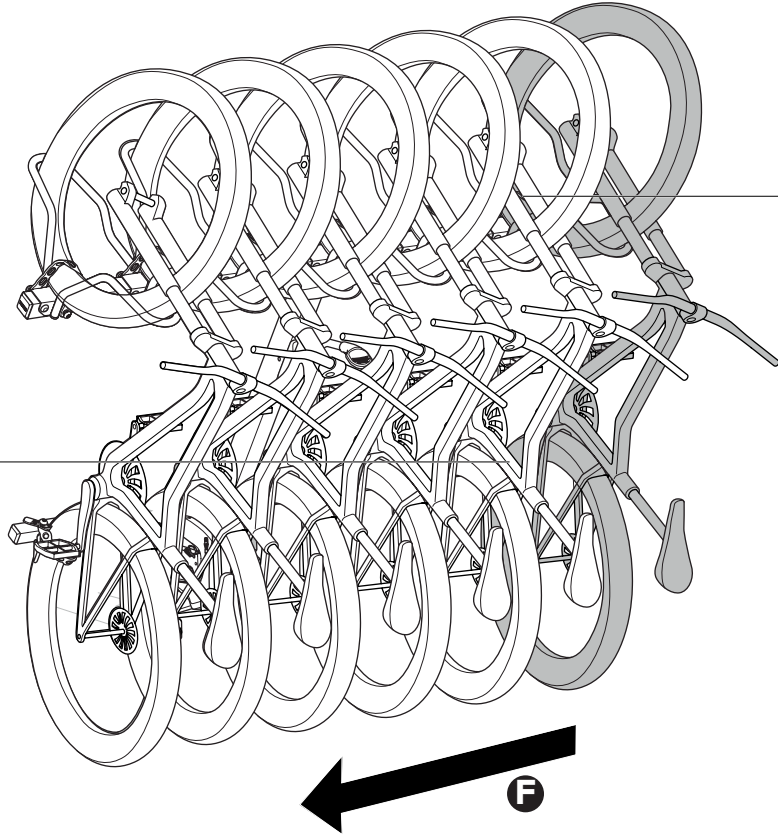
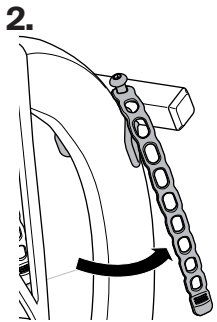
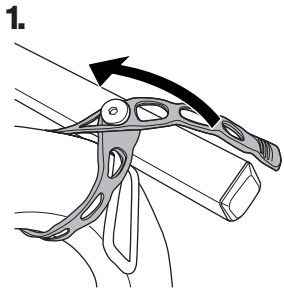

3.

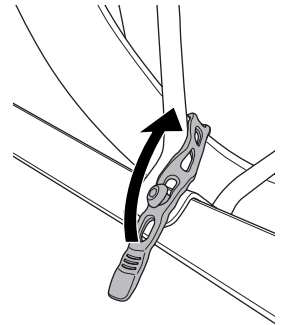

4.

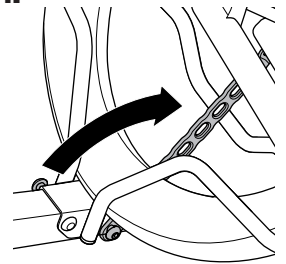

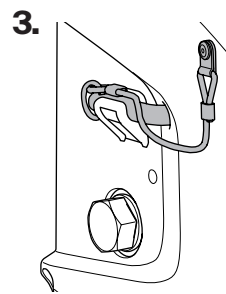
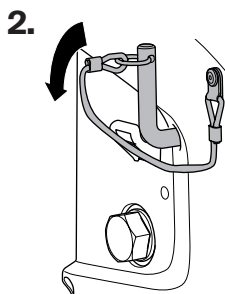
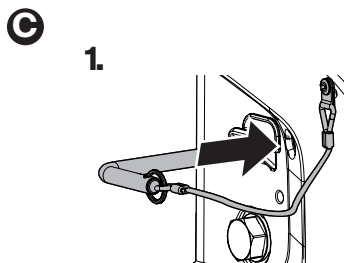
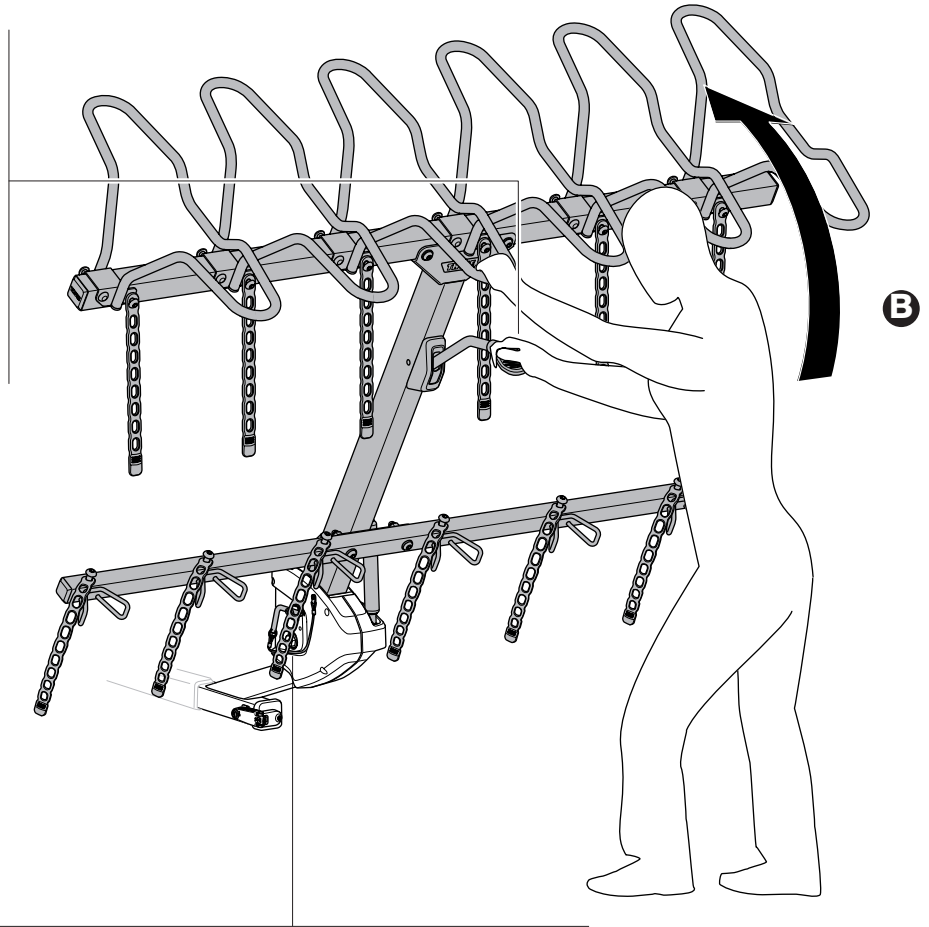
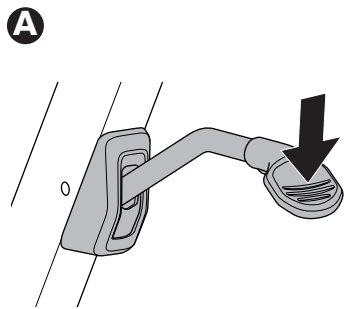
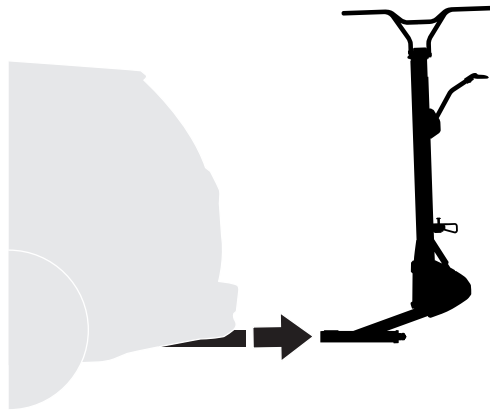

➔ **D**

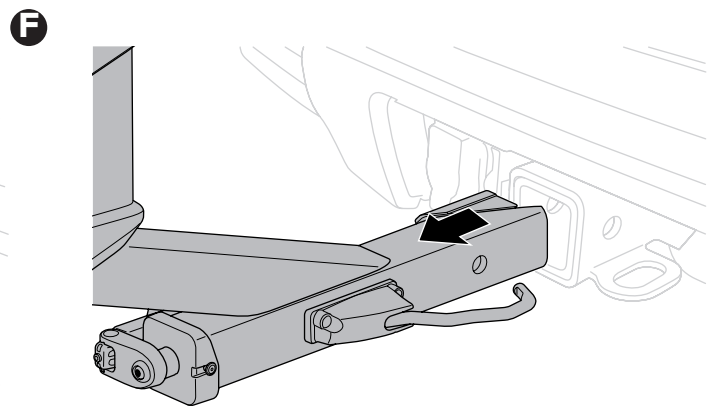
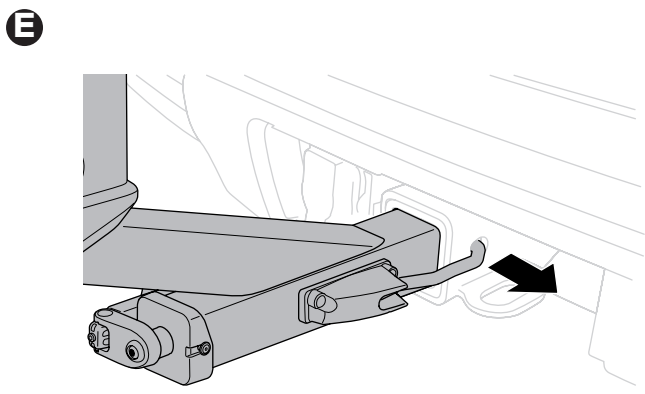
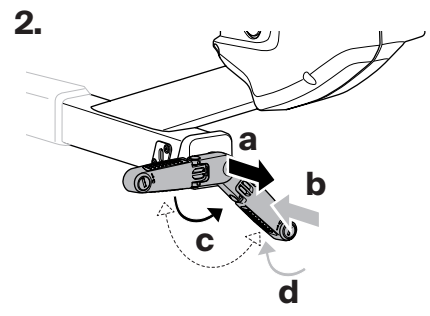
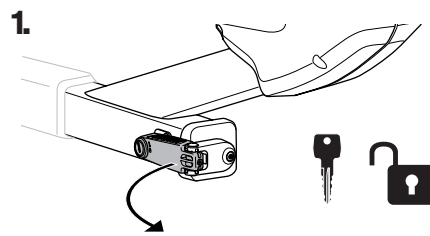
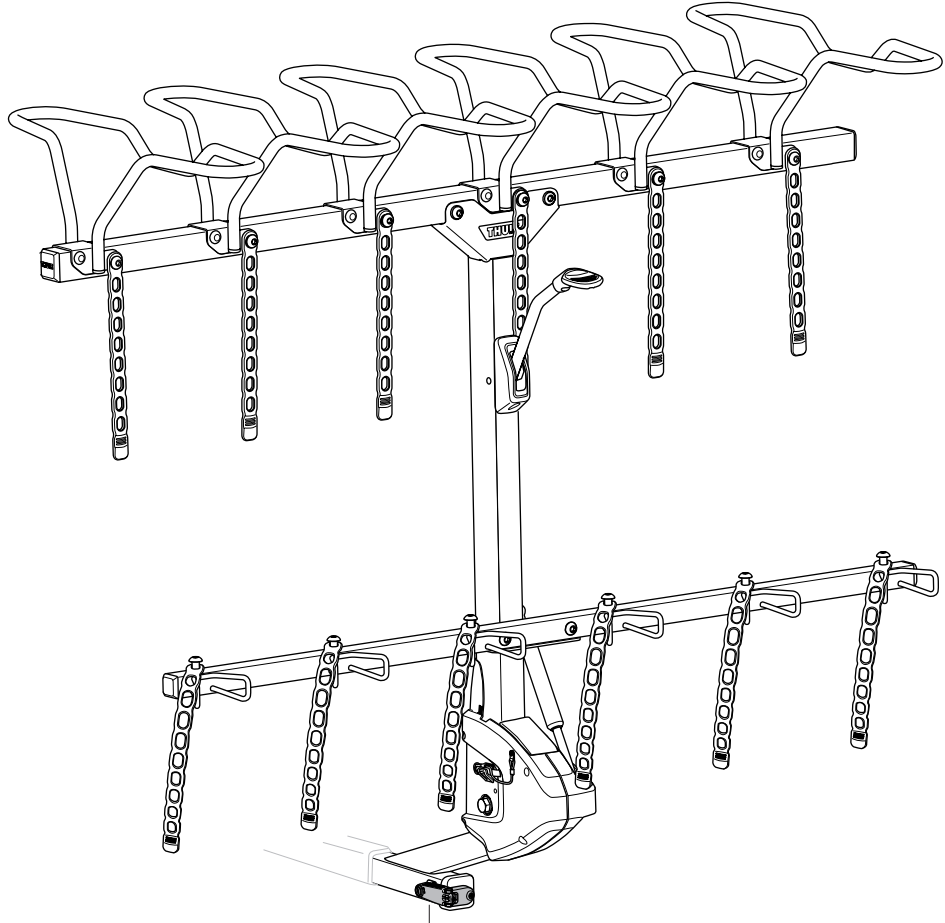

EN Accessories/Spare parts

FR Accessoires/Pièces de rechange

ES Accesorios/Repuestos

PT Acessórios/Peças de reposição

Thule Inc. 42 Silvermine Road, Seymour, CT 06483
Thule Canada Inc. 710 Bernard, Granby QC J2J 0H6
North American Consumer Service:
Toll Free 800-238-2388, Fax 450-777-3615
www.thule.com

© **Thule.** All rights reserved.
5564409001 | 2026-02-24 #01